

KD CSD50



HEAVY COMMERCIAL EVAPORATOR

Capacities:

- (1) 0°C ROOM, DT1 = 8K, R449A
- (2) -18°C ROOM, DT1 = 7K, R449A

Product description:

The KD CSD50 is a heavy commercial evaporator range with 6.0 mm fin spacing.

Product features:

- ▶ Pre fitted expansion valve on all models.
- ▶ Increased air throw with factory fitted air straightener.
- ▶ Low noise Ziehl-Abegg fan motor.
- ▶ Capacity range – 37.8 to 67.6 kw (SC2 Conditions)
- ▶ High efficiency inner grooved copper tube (DIA 1/2”).
- ▶ Powder coated galvanised steel casing.
- ▶ PVC Terminal Box (IP66)
- ▶ Electric defrost
- ▶ Double drain pan

ORDER ONLINE

www.thermofrostcryo.co.uk

Exclusive distributor
 **Thermofrost Cryo**

CSD50 Evaporator

Model Range

Model	Capacity	Capacity	Air throw m	Fan #	Motor input watts/hr	Refrigeration connections		Surface area m ²	Internal volume dm ³	Unit Weight Kg
	8K TD R449A	8K TD R407F				Inlet	Outlet			
CSD 50-270M3	37,837	37,870	43	3	2,310	7/8	2-1/8	117.9	36.9	227
CSD 50-360M3	50,547	50,581	42	3	2,310	1-1/8	2-1/8	157.2	49.2	252
CSD 50-380M3	50,664	50,699	46	4	3,080	1-1/8	2-1/8	157.2	48.7	288
CSD 50-480M3	67,624	67,661	44	4	3,080	1-1/8	2-1/8	209.7	64.9	320

Capacity at SC2 conditions (EN 328)

Duty correction factors

Room temp°C	-30	-25	-20	-15	-10	-5	0	5	10
T.D.5K	0.40	0.42	0.44	0.46	0.48	0.50	0.52	0.52	0.52
T.D.6K	0.52	0.55	0.58	0.61	0.63	0.66	0.68	0.68	0.69
T.D.8K	0.76	0.81	0.85	0.89	0.93	0.97	1.00	1.01	1.01
T.D.10K	-	-	1.11	1.17	1.22	1.27	1.31	1.32	1.33

Electrical data

Common data	Unit	270M3	360M3	380M3	480M3
Fans	N x Ømm	3 x 500	3 x 500	4 x 500	4 x 500
Total input	Watts	2,310	2,310	3,080	3,080
400v-3Ph-50Hz	Amps	5.1	5.1	6.8	6.8
Electric defrost	Watts	20,640	20,820	27,140	27,320
Electric power	Watts	380v-3ph	380v-3ph	380v-3ph	380v-3ph

Dimensions (mm)

Model number	Overall dimensions			Fixing dimensions			
	Length	Depth	Height	L"	W"	L1	L2
CSD50-270M3	2,950	519	761	2,601	621	1,732	869
CSD50-360M3	2,950	519	761	2,601	621	1,732	869
CSD50-380M3	3,800	519	761	3,451	621	1,725	1,725
CSD50-480M3	3,800	519	761	3,451	621	1,725	1,725

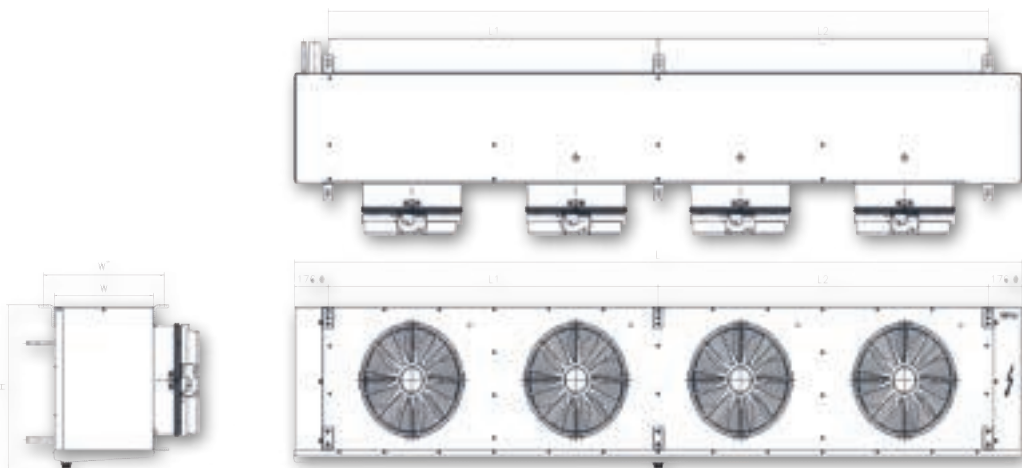

Heavy commercial cooler