

# Technical Data Sheet

Compressor model **NPT14RA**  
 Voltage **220-240V 50Hz ~1**  
 Refrigerant **R290**

## APPLICATION

## COMPRESSOR

## MOTOR

Application	High Back Pressure	Displacement	14,32 cm <sup>3</sup>	Nominal Power	1/2 hp
Refrigerant	R290	Diameter	29,37 mm	Voltage/Frequency	220-240V 50Hz
Evaporating Temp.	-15,0 °C to 10,0 °C	Stroke	21,13 mm	Voltage range	187-255 V
Expansion	Capillar/Valve	Net Weight	12,25 Kg	Type	CSR
Comp. Cooling	Fan cooled	Oil type	ISO VG 32 ESTER	Phase number	1 PH
Max. ambient temp.	43,0 °C	Oil charge	400 cm <sup>3</sup>	Locked Rotor Amps (LRA)	21,00 A
				Max. Cont. Current (MCC)	5,50 A
				Main W. resist. at 25°C	4,50 Ω
				Start W. resist. at 25°C	5,75 Ω

## NOMINAL PERFORMANCE

	ASHRAE	CECOMAF
Cooling Capacity	1.776 kCal/h	1.709 W
COP	2,69 W/W	2,26 W/W
EER	2,31 kCal/Wh	1,95 kCal/Wh
Input Power	769 W	756 W
Current	3,68 A	3,62 A

## APPROVALS



## TEST CYCLE CONDITIONS

	ASHRAE HBP (D)	CECOMAF HBP (C)
Evaporating temp. (T <sub>e</sub> )	7,2 °C	5,0 °C
Condensing temp. (T <sub>c</sub> )	55,0 °C	55,0 °C
Liquid temp. (T <sub>liq.</sub> )	46,0 °C	55,0 °C
Ambient temp. (T <sub>amb.</sub> )	35,0 °C	32,0 °C
Suction temp. (T <sub>suction</sub> )	35,0 °C	32,0 °C
Voltage/Frequency	220 V 50 Hz	220 V 50 Hz

## ELECTRICAL COMPONENTS

Starting capacitor	64- 77 µF 330 V		
Run capacitor	16 µF 420 V		
Relay	Option 1		
Reference	2014 166. + NTC15Ω		
Pick-Up	11,00 A		
Drop-Out	9,35 A		
Protector	Option 1	Option 2	
Reference	MRA38134	T0348	
Current	15,80 A	15,40 A	
Time check	7,5-14 seg	7,5-14 seg	
Disc temp. (Open/Close)	105,00 / 52,00 °C	105,00 / 52,00 °C	

This product is approved for R290 and R600a regarding explosion safety according to standard EN 60335-1 and EN 60335-2-34

## ASHRAE

Tc °C	Te °C	Cooling Capacity kCal/h	Consumption W	Current A	COP W/W	EER kCal/Wh
40	-15	828	483	2,48	1,99	1,72
40	-10	983	523	2,63	2,19	1,88
40	-5	1.191	562	2,78	2,47	2,12
40	0	1.453	599	2,93	2,82	2,42
40	5	1.768	635	3,08	3,24	2,78
40	7,2	1.923	651	3,15	3,44	2,96
40	10	2.136	670	3,23	3,71	3,19

45	-15	793	512	2,59	1,80	1,55
45	-10	945	555	2,76	1,98	1,70
45	-5	1.150	596	2,92	2,25	1,93
45	0	1.409	635	3,08	2,58	2,22
45	5	1.720	674	3,25	2,97	2,55
45	7,2	1.874	690	3,32	3,16	2,72
45	10	2.085	710	3,41	3,41	2,93

50	-15	759	542	2,70	1,63	1,40
50	-10	907	586	2,88	1,80	1,55
50	-5	1.109	630	3,06	2,05	1,76
50	0	1.364	672	3,24	2,36	2,03
50	5	1.673	712	3,42	2,73	2,35
50	7,2	1.825	730	3,50	2,91	2,50
50	10	2.034	751	3,60	3,15	2,71

55	-15	724	571	2,82	1,47	1,27
55	-10	870	618	3,01	1,64	1,41
55	-5	1.068	664	3,21	1,87	1,61
55	0	1.320	708	3,40	2,17	1,86
55	5	1.625	751	3,59	2,52	2,16
55	7,2	1.776	769	3,68	2,69	2,31
55	10	1.983	792	3,79	2,91	2,50

60	-15	690	601	2,94	1,34	1,15
60	-10	832	650	3,15	1,49	1,28
60	-5	1.027	698	3,35	1,71	1,47
60	0	1.276	744	3,56	1,99	1,71
60	5	1.577	789	3,78	2,32	2,00
60	7,2	1.727	809	3,87	2,48	2,14
60	10	1.932	833	3,99	2,70	2,32

## CECOMAF

Tc °C	Te °C	Cooling Capacity W	Consumption W	Current A	COP W/W	EER kCal/Wh
40	-15	890	485	2,49	1,84	1,59
40	-10	1.060	526	2,64	2,02	1,74
40	-5	1.285	565	2,80	2,27	1,96
40	0	1.566	603	2,95	2,60	2,24
40	5	1.902	639	3,10	2,98	2,57
40	7,2	2.068	655	3,17	3,16	2,73
40	10	2.294	674	3,25	3,40	2,94

45	-15	848	515	2,60	1,65	1,42
45	-10	1.012	558	2,77	1,81	1,57
45	-5	1.232	599	2,93	2,05	1,78
45	0	1.507	639	3,10	2,36	2,04
45	5	1.838	678	3,27	2,71	2,34
45	7,2	2.001	695	3,34	2,88	2,49
45	10	2.224	715	3,43	3,11	2,69

50	-15	805	545	2,72	1,48	1,28
50	-10	964	590	2,90	1,63	1,41
50	-5	1.178	634	3,08	1,86	1,61
50	0	1.448	676	3,26	2,14	1,85
50	5	1.773	717	3,44	2,47	2,14
50	7,2	1.934	734	3,52	2,63	2,28
50	10	2.154	756	3,62	2,85	2,46

55	-15	763	574	2,83	1,33	1,15
55	-10	916	622	3,03	1,47	1,27
55	-5	1.125	668	3,22	1,68	1,46
55	0	1.389	712	3,42	1,95	1,68
55	5	1.709	756	3,62	2,26	1,95
55	7,2	1.867	774	3,70	2,41	2,08
55	10	2.085	797	3,81	2,61	2,26

60	-15	720	604	2,95	1,19	1,03
60	-10	868	654	3,16	1,33	1,15
60	-5	1.071	702	3,37	1,53	1,32
60	0	1.330	749	3,59	1,78	1,53
60	5	1.645	794	3,80	2,07	1,79
60	7,2	1.801	814	3,89	2,21	1,91
60	10	2.015	838	4,01	2,40	2,08

## EN12900

X	Cooling Capacity (W)	Consumption (W)	Current (A)	Mass Flow (kg/h)
1	2.055,1051790211	319,0964738626	1,6649610278	15,58428083236
2	71,3988734565	3,9859531063	0,0069157901	0,60585583372562
3	-12,8006499105	7,5006851649	0,0334896945	0,059809613636697
4	1,0905963750	-0,0241844366	0,0000487430	0,017059409251323
5	-0,2612523683	0,0949591310	0,0006370623	0,0042584136361674

Equation	$x_1 + x_2Te + x_3Tc + x_4Te^2 + x_5TeTc$
----------	---

# Technical Data Sheet

## COMPRESSOR DIMENSIONS

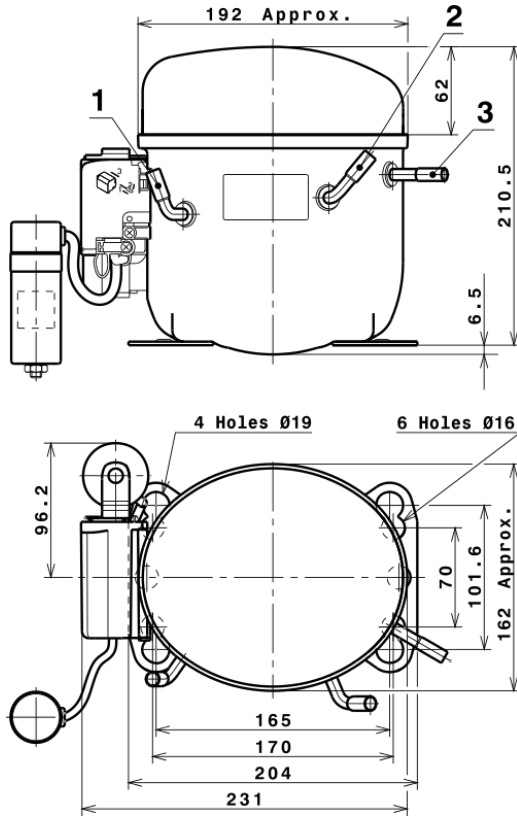

DESIGNATION	INTERNAL DIAM.
1 Suction	8,1 mm
2 Service	8,1 mm
3 Discharge	6,5 mm

## WIRING DIAGRAMS AND ELECTRICAL ASSEMBLY

### CSR CONNECTION (CURRENT RELAY + NTC) (L, P ranges)

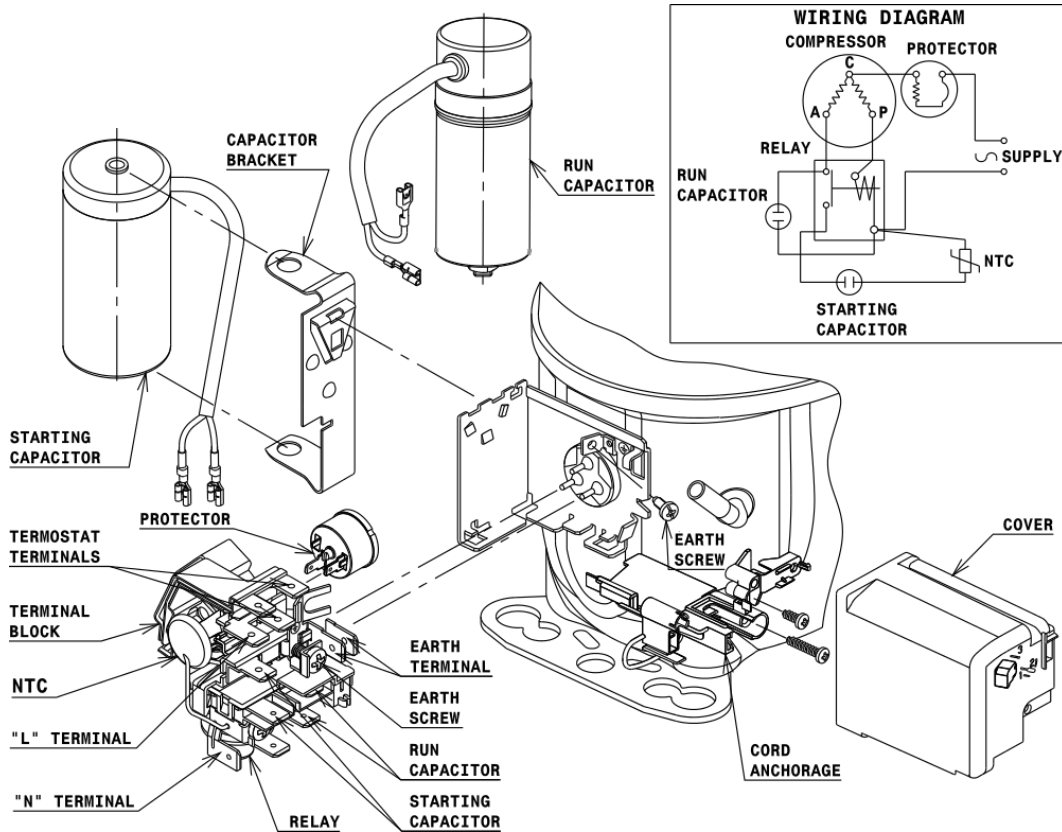

# Technical Data Sheet

## FIXINGS



## SILENT BLOCKS (MOUNTING ACCESSORIES)

### STANDARD

Ø16 holes (170x70 net)



### AMERICAN FEET

Ø19 holes (165x101.6 net)

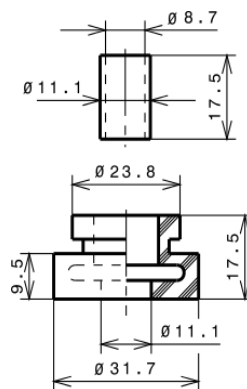

### SNAP-ON

Ø16 holes (170x70 net)



## SOA

SOA R290 HBP

