

Life Is On

eliwell[™]
by Schneider Electric

COLDFACE

Certified controllers and switchboards for cold rooms



www.eliwell.com



COLDFACE

Certified controllers and switchboards for cold rooms

Coldface series Controllers and switchboards provide control of all static or ventilated cold room functions in a single device, with both single-phase and three-phase loads.

The enclosure, with innovative design for on-board installation, combines ease of installation, water resistance and the capability to house all electromechanical devices required for correct cold room load control and protection.

The versions with door on the front panel allow direct access to the load protection circuit breakers.

The controllers are available with a series of advanced functions, such as HACCP event logging with a yearly calendar, Pump Down control and programmed defrosts.

The Coldface range is certified compliant with the EN61439 - EN60204 standards for low-voltage switchgear for installation on machinery.



Typical applications

- › Butchers
- › Delicatessens
- › Catering
- › Hotels
- › Dairies
- › Pasta producers
- › Wineries
- › Cold stores
- › Distribution centres
- › Greengrocers



- 1 EWRC 5000 NT
EWRC 5010 NT
EWRC 5030 NT
- 2 EWRC 300 - 500 NT
- 3 EWRC 500 NT 4D
- 4 IDPanel 978



2



3



4

Plus points



Easy installation

Coldface series controllers and switchboards are easy to install thanks to the following features:

- Fast wiring thanks screw or spring-clamp terminal blocks, direct power supply and large space inside the enclosure
- Guided wall-mounted application for the easiest installation
- Direct access to the manual-reset load protection circuit breakers



User-friendliness

Coldface series controllers and switchboards are easy and intuitive to use thanks to the following features:

- Intuitive user interface
- Direct access to the most used parameters
- Double high-visibility display
- Luminous icons and six large-size keys for direct access to functions



Quick start-up and supervision tools

- Compatibility with Eliwell TelevisGo and TelevisiBlue supervision systems
- Thanks to the Modbus protocol, Coldface is also compatible with third-party supervision systems
- Adaptation to specific applications is fast using UNICARD programming and the DeviceManager software.



The large LED display allows constant monitoring of cold room status

Plus points



Benefits

- Direct control of single-phase or three-phase compressors up to 20A
- Single-phase versions up to 5 relay outputs configurable for the complete control of all loads
- Models with clock for programmed defrosts and HACCP functions with yearly calendar
- Easy wall installation, wirings and commissioning
- Highly configurable for every application need
- Large LED display for an immediate view of cold room status
- User-friendly keyboard and associated functions
- Flame retardant enclosure with high internal capacity, resistant to water splashes
- Connectivity to Televis and Modbus monitoring systems provided as standard
- Certified compliant with the European directives covering low-voltage switchgear for installation on machinery.



EWRC 5000 - 5010 - 5030

Everything under control

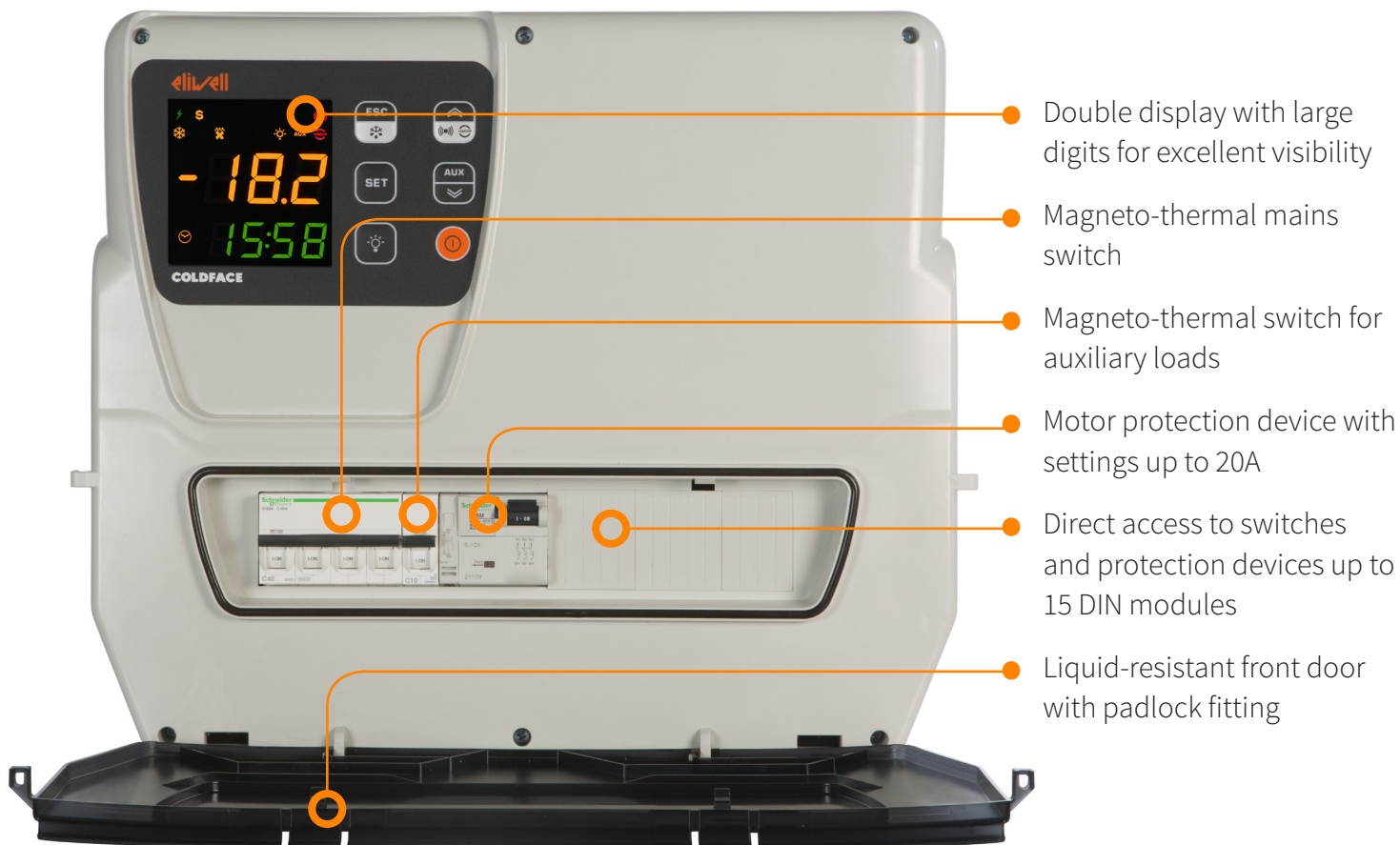

EWRC 5000 - 5010 - 5030

Plenty of wiring space

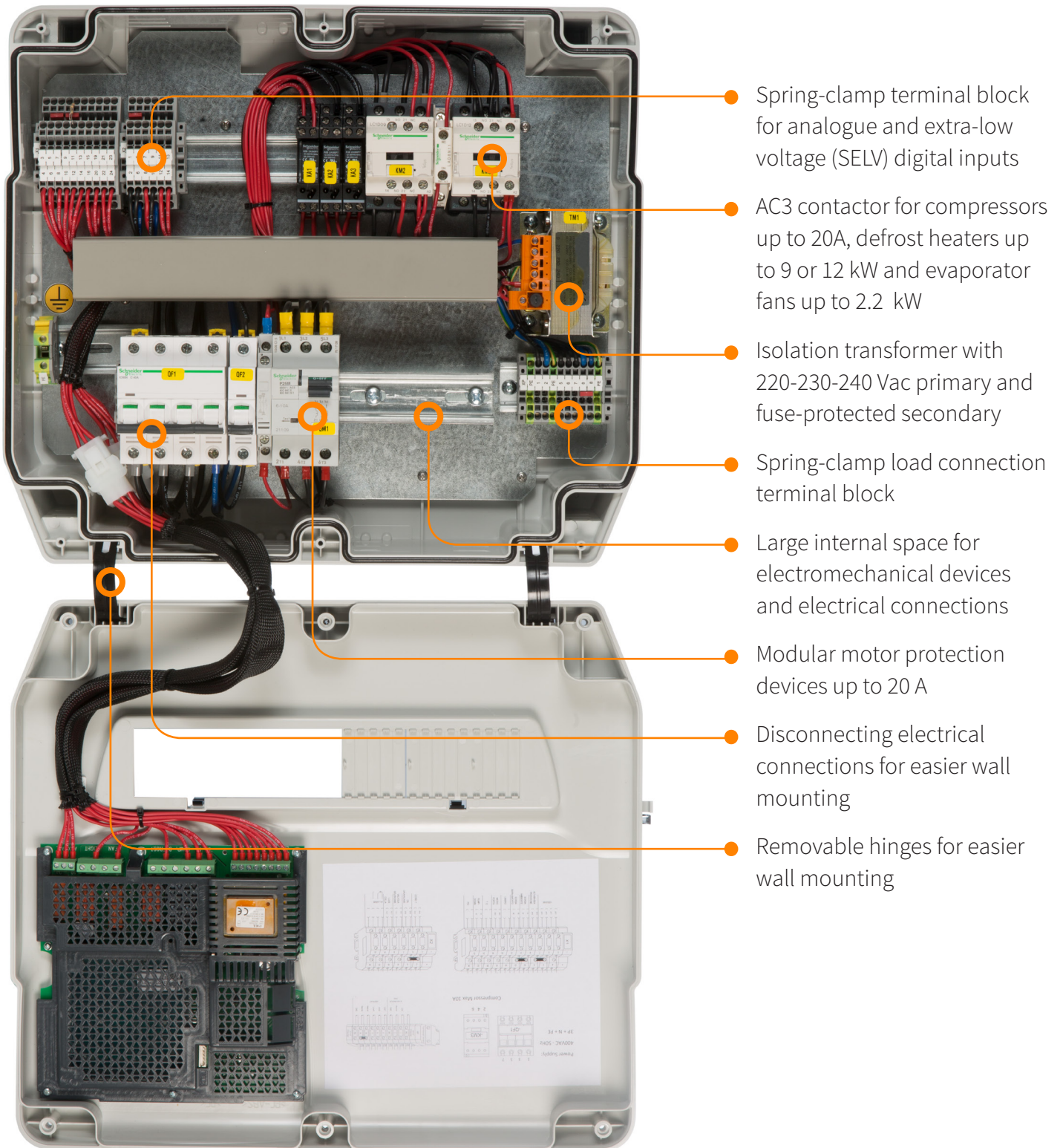

- Spring-clamp terminal block for analogue and extra-low voltage (SELV) digital inputs
- AC3 contactor for compressors up to 20A, defrost heaters up to 9 or 12 kW and evaporator fans up to 2.2 kW
- Isolation transformer with 220-230-240 Vac primary and fuse-protected secondary
- Spring-clamp load connection terminal block
- Large internal space for electromechanical devices and electrical connections
- Modular motor protection devices up to 20 A
- Disconnecting electrical connections for easier wall mounting
- Removable hinges for easier wall mounting

EWRC 5000 - 5010 - 5030

General specifications

Line of electrical switchboards for complete control of cold rooms, single-phase or three-phase, with direct compressor control with variable setting protection device, evaporator fan, defrost heater, condenser fan, solenoid valve, cold room light and compressor oil heater.

Front door providing water-splash protection for the interior accommodating up to 15 DIN modules, with direct access to the magneto-thermal switches and variable setting motor protection device.

Thermostat or Pump-Down compressor control.

All connections are on convenient spring-clamp terminal blocks, which combine with efficient enclosure layout for quick, easy electrical connections.

The electronic controller features a series of leading-edge functions, such as HACCP event logging with a yearly calendar.

Connection to Televis or ModBus supervision systems possible with opto-isolated plug-in accessory.

The default configuration covers most applications but offers a high degree of customisation to individual requirements by the installer.

The product is certified compliant with the European directives regulating low-voltage switchgear for installation on machinery (EN61439 - EN60204).



EWRC 5000 - 5010 - 5030

Technical data



	EWRC 5000 NT	EWRC 5010 NT	EWRC 5030 NT
Dimensions	450x380x160 mm		
Enclosure	PC + ABS		
Enclosure rating	IP65		
Installation	Wall		
Display	3 digits + sign and 4 digits		
Display range	NTC: -50...110 °C / PTC: -55...150 °C		
Resolution	0.1 °C		
Analogue inputs	3 x NTC / PTC*		
Digital inputs	2 voltage-free inputs		
Control type	Single-phase		Three-phase
Connections	Screw terminals	Screw terminals on DIN rail	
Auxiliary protection	-	Specific magneto-thermal switch	
RTC	Present		
HACCP	Present		
Connectivity	TTL and RS485** port for Unicard, TelevisSystem and Modbus RTU systems		
Power supply	230 Vac +/-10 % 50/60 Hz	230 Vac (phase + neutral + ground)	400 Vac (3phase + neutral + ground)
Mains switch	-	Two-pole magneto-thermal switch	Four-pole magneto-thermal switch
Operating temperature	-5...35 °C (Max 40 °C non continuous)		
Operating humidity	10...90 % RH (non condensing)		

* configurable by user - ** with optional plug-in accessory

Table of codes

Code	Description	Notes
RCH300DTX*700	EWRC 5000 NT HACCP BZ 230Vac	Electronic Controller only
RCH301DTX*700	EWRC 5010 NT HACCP BZ 2.5-4A 230Vac	HACCP/Buzzer/RTC
RCH302DTX*700	EWRC 5010 NT HACCP BZ 4-6.3A 230Vac	HACCP/Buzzer/RTC
RCH303DTX*700	EWRC 5010 NT HACCP BZ 6-10A 230Vac	HACCP/Buzzer/RTC
RCH304DTX*700	EWRC 5010 NT HACCP BZ 13-18A 230Vac	HACCP/Buzzer/RTC
RCH305DTX*900	EWRC 5030 NT HACCP BZ 2.5-4A 400Vac	HACCP/Buzzer/RTC
RCH306DTX*900	EWRC 5030 NT HACCP BZ 4-6.3A 400Vac	HACCP/Buzzer/RTC
RCH307DTX*900	EWRC 5030 NT HACCP BZ 6-10A 400Vac	HACCP/Buzzer/RTC
RCH308DTX*900	EWRC 5030 NT HACCP BZ 9-14A 400Vac	HACCP/Buzzer/RTC
RCH309DTX*900	EWRC 5030 NT HACCP BZ 13-18A 400Vac	HACCP/Buzzer/RTC
RCH310DTX*900	EWRC 5030 NT HACCP BZ 17-20A 400Vac	HACCP/Buzzer/RTC
RCH311DTX*900	EWRC 5030 NT HACCP BZ 6 kW	HACCP/Buzzer/RTC/Evaporator with 6 kW electric defrost system
RCH312DTX*900	EWRC 5030 NT HACCP BZ 12 kW	HACCP/Buzzer/RTC/Evaporator with 12 kW electric defrost system

*The number in this position indicates the language available for the code: 1: ITA-ENG 2: ENG-AR 3: ITA-SPA 4: FRA-GER 5: GRE-RUS

EWRC 300 NT - EWRC 500 NT

General specifications

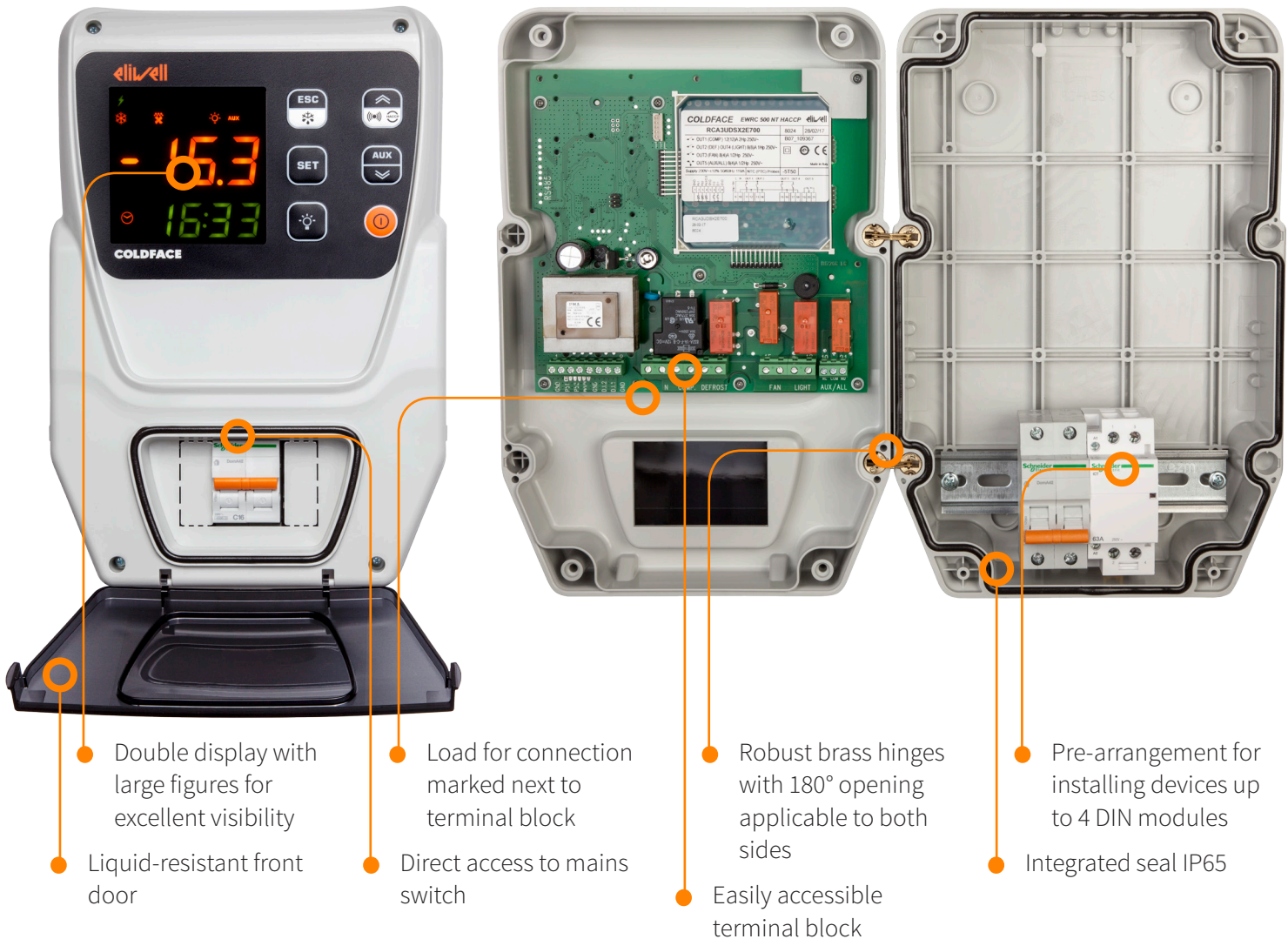

Line of electronic controllers for single-phase cold rooms, with direct control of compressors up to 2 HP, evaporator fan, defrost heater, cold room light and alarm.

Front door providing water-splash protection for the interior accommodating up to 4 DIN modules, with direct access to the magneto-thermal mains switch.

Connection to Televis or ModBus supervision systems possible with opto-isolated plug-in accessory.

The product is certified compliant with the European directives regulating low-voltage switchgear for installation on machinery (EN61439 - EN60204).

EWRC 300 NT - EWRC 500 NT

Technical data



	EWRC 300 NT	EWRC 500 NT	EWRC 500 NT BREAKER
Dimensions	213x318x102 mm		221x318x107 mm
Enclosure	PC + ABS		
Enclosure rating	IP65		
Installation	Wall		
Display	3 digits + sign and 4 digits		
Display range	NTC: -50...110 °C / PTC: -55...150 °C		
Resolution	0.1 °C		
Analogue inputs	3(2) x NTC / PTC*		
Digital inputs	2(3) voltage-free		
Digital outputs (default config. *)	12(12) A 2 HP 250 Vac SPST		
Compressor			
Defrost	8(8) A 1 HP 250 Vac SPST		
Evaporator fan	8(4) A ½ HP 250 Vac SPST		
Light	-	8(8) A 1 HP 250 Vac SPST	
Alarm	-	8(4) A ½ HP 250 Vac SPST	
Connections	Screw-type		
RTC Clock	Optional		
HACCP	Optional		
Connectivity	RS-485 Televis/ Modbus		
Power supply	230 Vac / 11 VA		
Interruttore	-	230 Vac Icn 4500 A 2P	
Nominal current	-	In = 16 A	
Pulse voltage	-	4 KV	
Operating temperature	-5...+50 °C		
Operating humidity	10...90 % RH (non condensing)		

* configurable by user

Table of codes

Code	Description	Notes
RCS3HDLX2*700	EWRC 300 NT 2HP BUZZER	Buzzer
RCS3UDLX2*700	EWRC 500 NT 2HP BUZZER	Buzzer
RCS3UDTX2*700	EWRC 500 NT 2HP RTC HACCP BUZ	HACCP/Buzzer/RTC
RCA3UDRX2*700	EWRC 500 NT 2HP BUZ 4DIN W/B	Buzzer/Circuit Breaker
RCA3UDSX2*700	EWRC 500 NT 2HP RTC HACCP BUZ 4DIN W/B	HACCP/Buzzer/Circuit Breaker/RTC
KP00Q1S0	RS485 Plugin 40x49mm screw terminals	Optional module

* The number or letter in this position indicates the language available for the code:
 0: ITA; E: ENG; F: FRA; G: GER; O: POL; R: RUS; S: SPA; T: TUR; U: Arabic; W: SWE; Z: BRA

IDPanel 978

General specifications

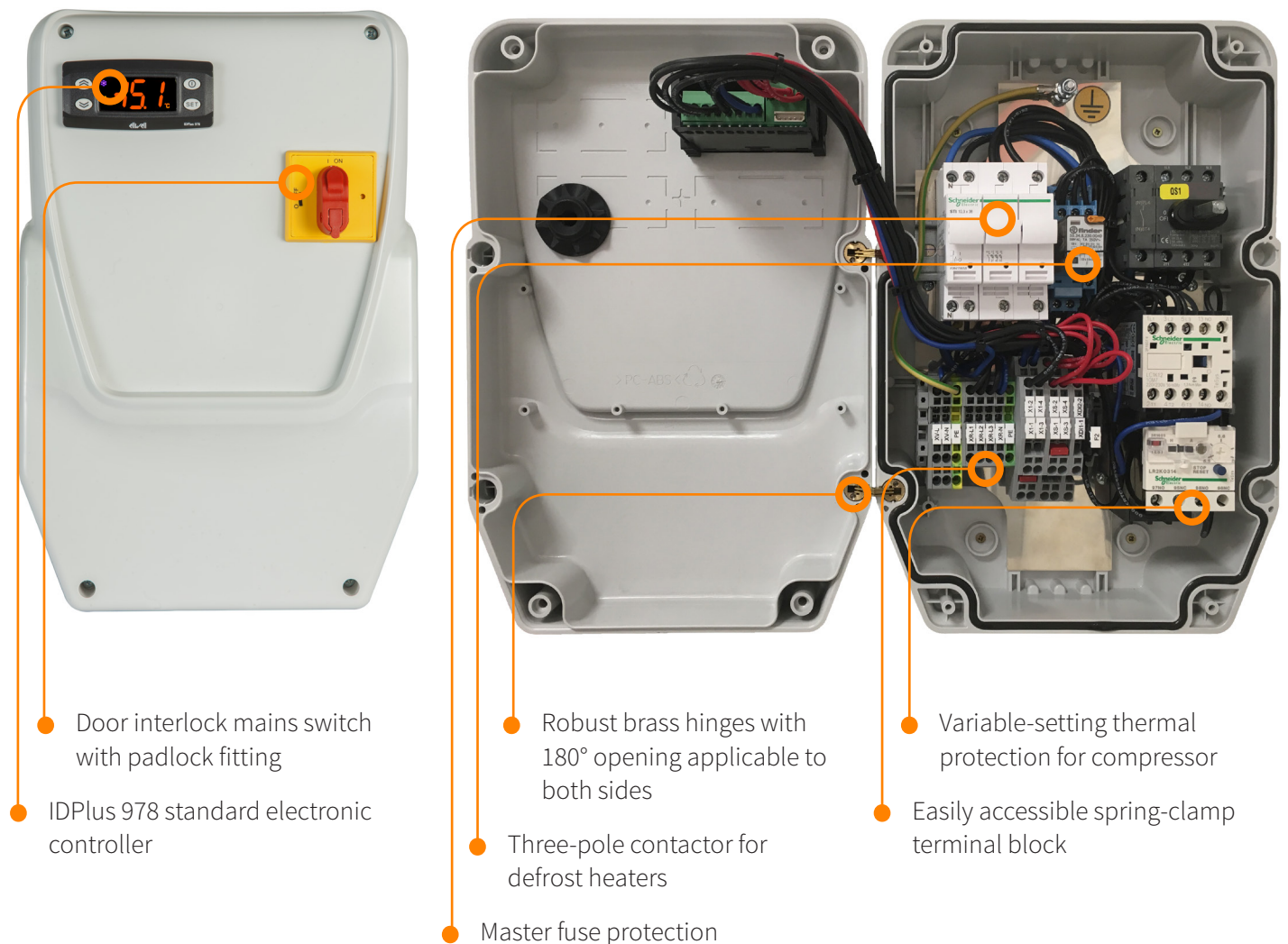

Line of electrical switchboards for complete control of cold rooms, single-phase or three-phase, with direct control of compressor with variable-setting thermal protection, evaporator fan, defrost heater and cold room light. The use of the widely adopted, well known IDPlus 978 standard controller ensures extremely simple commissioning and use.

All connections are on convenient spring-clamp terminal blocks, which combine with efficient enclosure layout for quick, easy electrical connections.

The electronic controller can be connected to Televis or ModBus supervision systems by means of the BusAdapter external accessory.

The product is certified compliant with the European directives regulating low-voltage switchgear for installation on machinery (EN61439 - EN60204).

IDPanel 978

Technical data



	IDPanel 978 5.5-8A 230 Vac	IDPanel 978 8-11A 230 Vac	IDPanel 978 3.7-5.5A 400 Vac	IDPanel 978 5.5-6 A 400 Vac
Dimensions	213x318x102 mm			
Enclosure	PC + ABS			
Installation	Wall			
Display	3Digits + sign			
Display range	NTC: -50...110 °C / PTC: -55...140 °C / Pt1000: -55...150 °C			
Resolution	0.1 °C			
Analogue inputs	2 PTC / NTC / Pt1000*			
Digital inputs	1 digital (SELV) / analogue (PTC / NTC / Pt1000) / 1 digital (SELV) / serial TTL*			
Control type	Single-phase		Three-phase	
Compressor	1PH 5.5 - 8.0 A	1PH 8.0 -11.0 A	3PH 3.7 - 5.5 A	3PH 5.5 - 6.0 A
Defrost	1PH 800 W		3PH 2400 W	
Evaporator fan	1PH 800 W			
Light	1PH 800 W			
Connections	Screw terminals on DIN bar			
Connectivity	TTL port for connection to Unicard/Copycard or TelevisSystem/ModBus monitoring device*			
Power supply	230 Vac (phase + neutral + ground)		400 Vac (3phase + neutral + ground)	
Door interlock mains switch	25 A			
Operating temperature	-5...+40 °C			
Operating humidity	10...90 % RH (non condensing)			
General protection	Fuses			
Motor protection	Thermal relay			

* configurable by user

Table of codes

Code	Description	Notes
ELP300DSX0700	IDPanel 978 5.5-8A 230Vac	HACCP/Buzzer
ELP301DSX0700	IDPanel 978 8-11A 230Vac	HACCP/Buzzer
ELP302DSX0900	IDPanel 978 3.7-5.5A 400Vac	HACCP/Buzzer
ELP303DSX0900	IDPanel 978 5.5-6A 400Vac	HACCP/Buzzer

Functional diagrams

EWRC 5010 NT

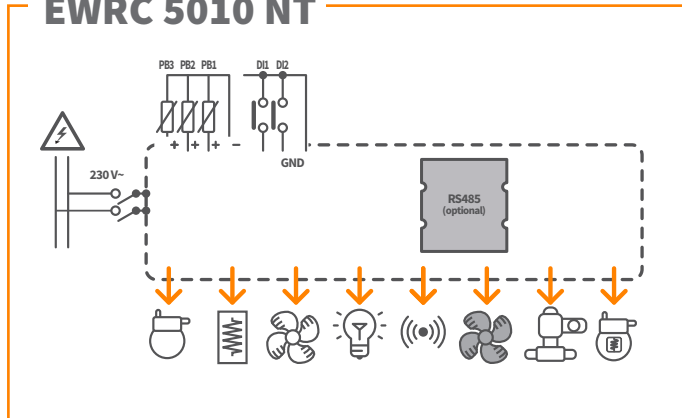

EWRC 5030 NT

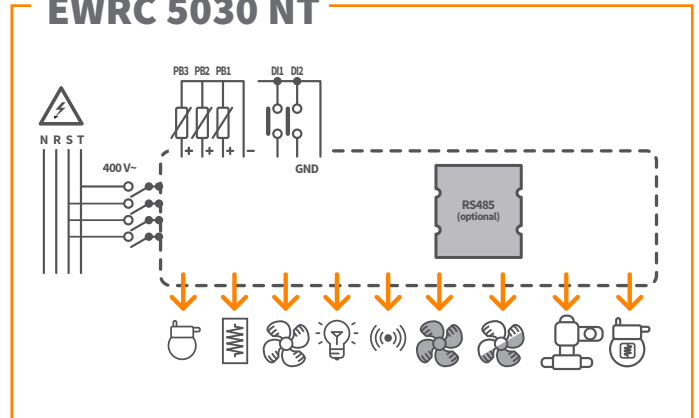

EWRC 300 - 500 NT

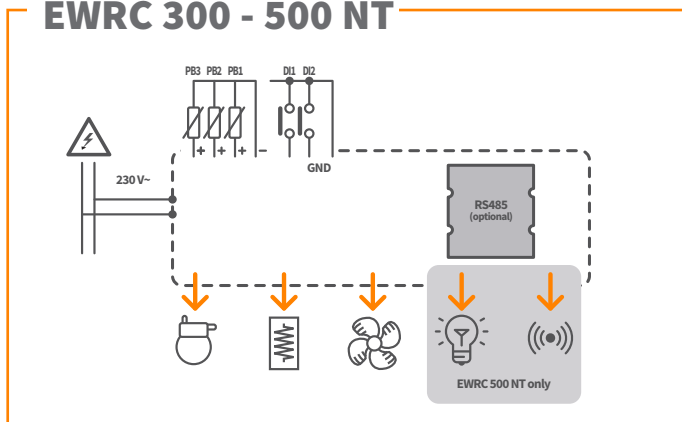

EWRC 500 NT 4D

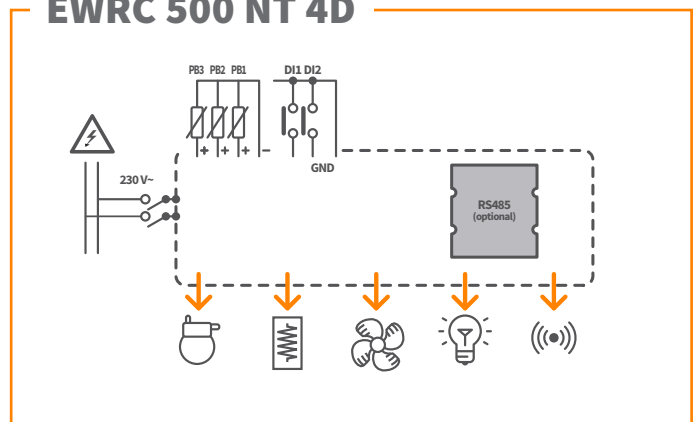

IDPanel 978

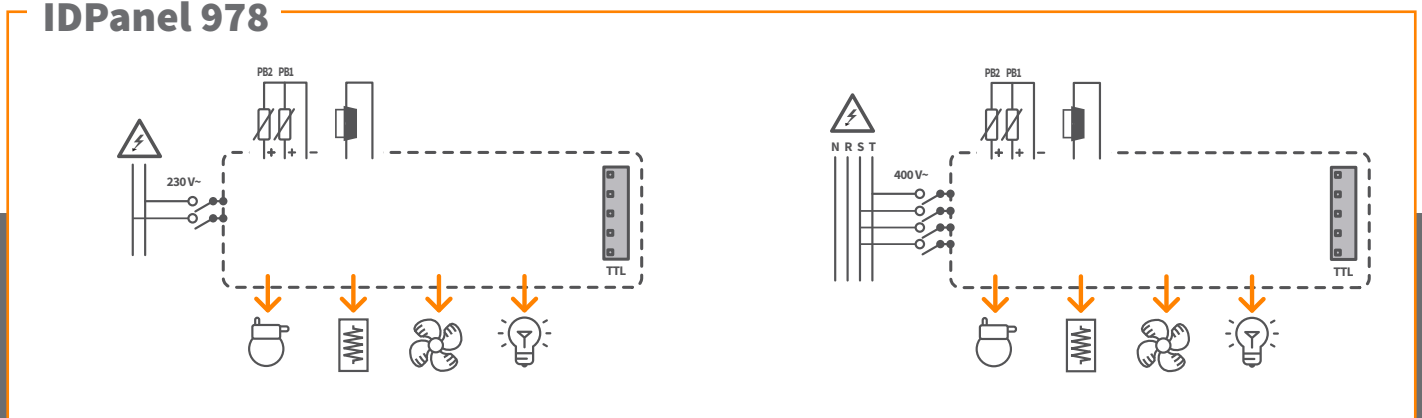

Accessories

Interfaces, programming keys

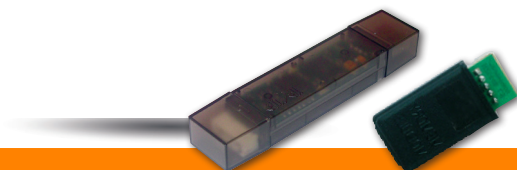

Code	Description
CC0S00A00M000	Copy Card Programming key for loading/downloading parameters
CCA0BHT00UU00	UNICARD USB/TTL

Temperature probes



Code	Description
SN691150	1.5m thermoplastic rubber cable NTC IP68 and 5X20mm thermoplastic tip
SN8DED11502C0	1.5m thermoplastic rubber cable NTC IP68 and 5X20mm thermoplastic tip
SN8DAE11502C0	1.5m thermoplastic rubber cable NTC IP68 and 6X20mm Steel tip
SN8DED13002C0	3m thermoplastic rubber cable NTC IP68 and 6X20mm Steel tip
SN8DAE13002C0	3m thermoplastic rubber cable NTC IP68 and 6X20mm Steel tip

RS485 plug-in (for EWRC 300 - 500 - 5010 - 5030 NT)

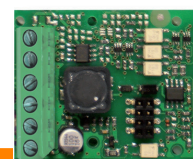

Code	Description
KP00Q1S0	RS485 Plug-in 40x49mm screw terminals

Other accessories (for EWRC 300 - 500 and IDPanel 978)

Code	Description
ZZ000292	Plug cover TDI 20 (12pcs)
ZZ000291	Brass hinge (12 pcs)



Correlated products

LKD Detection and indication of refrigerant leaks



The state-of-the-art **LKD** series gas sensors can detect a wide range of gases and refrigerants depending on the model: NH3, HFO, HC, HFC and CO2.

LKD series gas sensors can be used alone to control a buzzer, siren, etc., or integrated with Eliwell or third party remote management systems, thanks to an inbuilt RS485 ModBus.

The main applications are: LT or NT cold rooms, refrigerated cabinets and compressor units.

Code	Description	Power supply
LKD41CO2XR400	LKD 100 mod110 CO2	12/24 V
LKD41xxxxR400	LKD 100	12/24 V
LKD66CO2XR400	LKD 200 mod210 CO2	12/24 V
LKD66xxxxR400	LKD 200	12/24 V
LKDR4CO2XR400	LKD 100 mod110 5m remote CO2	
LKDR4xxxxR400	LKD 100 5m remote	
LKDSG00000000	LKD Splash Guard	-

xxxx = R220 / R134 / R290 / R404 / R4A7 / R4F7 / R410 / R448 / R449 / R450 / R507 / R513 / R600 / NH3X depending on compatible refrigerant type.

TelevisBlue Cloud solution for installations monitoring



TelevisBlue is the innovative system for completely cloud-based monitoring of small and medium-sized installations, which uses its protected M2M cellular network data connection to transfer data between the installation and the cloud with no need for configuration by the user.

TelevisBlue offers the power of cloud data collection service, accessible via the web, with simple, speedy installation via a pre-activated kit.

CAUTION: the use of the TelevisBlue product and service is subject to acceptance of the terms of service posted on the site www.televisblue.com/terms. For more information on system characteristics, countries where the service is available, and connectible controllers, see the online manual and appendices at www.televisblue.com/help.

Code	Description	Notes
TBR2S**1E0000	TelevisBlue Starter 1Y 2G	12 months' service included Monitoring, Reports and Alarms, Centralised data access
TBR2P**1E0000	TelevisBlue Plus 1Y 2G	12 months' service included Monitoring, Reports and Alarms, Centralised data access and Controller remote maintenance*
SAMANT3B30300	ANTENNA 3B 3m CABLE MCX90/M	Optional external antenna
TBR2X0000GW00	TelevisGate 2G	Only replacement device

** The two figures refer to the maximum number of resources controlled: 01=5; 05=25; 10=50; 30=150; 50=250; 1H=500 resources. Service available in a limited number of Countries. See on-line manual for updated list



Life Is On



ITALY - HEADQUARTERS

Eliwell Controls Srl

Via dell' Industria, 15 Z. I. Paludi
32016 Alpago (BL) - Italy
T +39 0437 986 111

Sales

T +39 0437 986 100 (Italy)
T +39 0437 986 200 (other countries)
E saleseliwell@schneider-electric.com

Technical support

T +39 0437 986 300
E techsuppeliwell@schneider-electric.com



Contact us!



www.eliwell.com

Follow us on



CT123387 • rel. 09/17
© Copyright Eliwell Controls s.r.l. 2017 - All rights reserved.

Eliwell has been making control systems and services for commercial and industrial refrigeration and air conditioning units for more than 35 years, offering highly innovative and technologically advanced products. Eliwell is a company of the Schneider Electric Group. Subscribe to our newsletter on the site www.eliwell.com.