

SANYO

SANYO SCROLL COMPRESSORS

Code : 809 193 88

Model : C-SCN673H8K



DALIAN SANYO COMPRESSOR CO.,LTD.

Rev.2010-05

SANYO Scroll Compressor



Model C-SCN673H8K

Refrigerant R407C

Electrical 380-415 Volts 3 Phase 50Hz

440-460 Volts 3 Phase 60Hz

Nominal Performance at ARI

Power Source	<u>50Hz-380V</u>	<u>60Hz-440V</u>
Capacity (W)	<u>26500</u>	<u>32000</u>
Power (W)	<u>8500</u>	<u>10450</u>
Current (A)	<u>14.4</u>	<u>14.9</u>
COP (W/W)	<u>3.12</u>	<u>3.06</u>
Mass Flow (kg/h)	<u>-</u>	<u>-</u>

Rating Conditions (MID Point)

Condensing Temperature(°C)	<u>54.4</u>
Evaporating Temperature(°C)	<u>7.2</u>
Return Gas temperature(°C)	<u>18.3</u>
Liquid Temperature(°C)	<u>43.8</u>
Ambient Temperature(°C)	<u>35</u>

Motor

	<u>50Hz</u>	<u>60Hz</u>
Voltage Range(V)	<u>342-456</u>	<u>396-506</u>
RLA (A)	<u>-</u>	<u>-</u>
MCC (A)	<u>-</u>	<u>-</u>
LRA (A)	<u>80</u>	<u>84</u>
RPM (min ⁻¹)	<u>2900</u>	<u>3450</u>

Compressor

Maximum Discharge Temp(°C)	<u>135</u>
Displacement (cm ³ /rev)	<u>148.8</u>
Weight (with oil kg)	<u>68</u>

Oil

Oil Type	<u>FV68S</u>
Initial Charge (ml)	<u>2800</u>
Re-charge (ml)	<u>2600</u>

Electrical Components

Motor Protector Type	<u>Internal</u>
Run Capacitor Rating (MFD/Volts)	<u>n/a</u>

Nominal performance values +/-5% with 1 hr run-in.

Ratings with air over compressor.

Specifications subject to change without notice.



Made by: Dalian **SANYO** Compressor Co., Ltd.



PERFORMANCE DATA

Compressor Model	C-SCN673H8K
Power Source	3PH 50Hz 380~415V
Suction Gas Superheat(K)	9
Sub Cooling(K)	8.3
Compressor Cooling	Natural Cooling
Refrigerant	R407C

CAPACITY(W)

Condensing Temperature(°C)	Evaporating Temperature(°C)							
	-15	-10	-6.7	0	4.4	7.2	10	12
35.0	13,980	17,330	19,960	26,600	32,120	36,220	40,840	44,500
40.5	12,970	16,020	18,420	24,470	29,470	33,180	37,360	40,660
45.0	12,180	15,020	17,240	22,830	27,450	30,860	34,710	37,740
50.0	11,360	13,970	16,010	21,130	25,350	28,460	31,960	34,720
54.4		13,100	15,000	19,730	23,630	26,500	29,720	32,260
60.0			13,800	18,090	21,610	24,200	27,100	29,380
65.0				16,760	19,980	22,340	24,980	27,060

POWER(W)

Condensing Temperature(°C)	Evaporating Temperature(°C)							
	-15	-10	-6.7	0	4.4	7.2	10	12
35.0	5,440	5,550	5,600	5,680	5,710	5,710	5,710	5,700
40.5	5,970	6,120	6,200	6,320	6,360	6,370	6,380	6,380
45.0	6,460	6,650	6,750	6,900	6,970	6,990	7,000	7,000
50.0	7,050	7,290	7,420	7,630	7,720	7,760	7,780	7,790
54.4		7,910	8,070	8,330	8,450	8,500	8,540	8,550
60.0			8,980	9,310	9,470	9,540	9,600	9,620
65.0				10,270	10,470	10,560	10,630	10,670

CURRENT(A) @380V

Condensing Temperature(°C)	Evaporating Temperature(°C)							
	-15	-10	-6.7	0	4.4	7.2	10	12
35.0	9.8	10.0	10.0	10.1	10.1	10.1	10.1	10.1
40.5	10.7	10.9	11.0	11.1	11.2	11.2	11.2	11.2
45.0	11.4	11.7	11.8	12.0	12.1	12.1	12.1	12.2
50.0	12.3	12.6	12.8	13.1	13.2	13.3	13.3	13.3
54.4		13.5	13.8	14.1	14.3	14.4	14.5	14.5
60.0			15.1	15.6	15.8	15.9	16.0	16.1
65.0				17.0	17.3	17.4	17.6	17.6

NOTE:

- * The performance values are based on MID point method.
- * The performance values subject to change without notice.

Compressor Model(Code)
Power Source

C-SCN673H8H
3PH 50Hz 380~415V

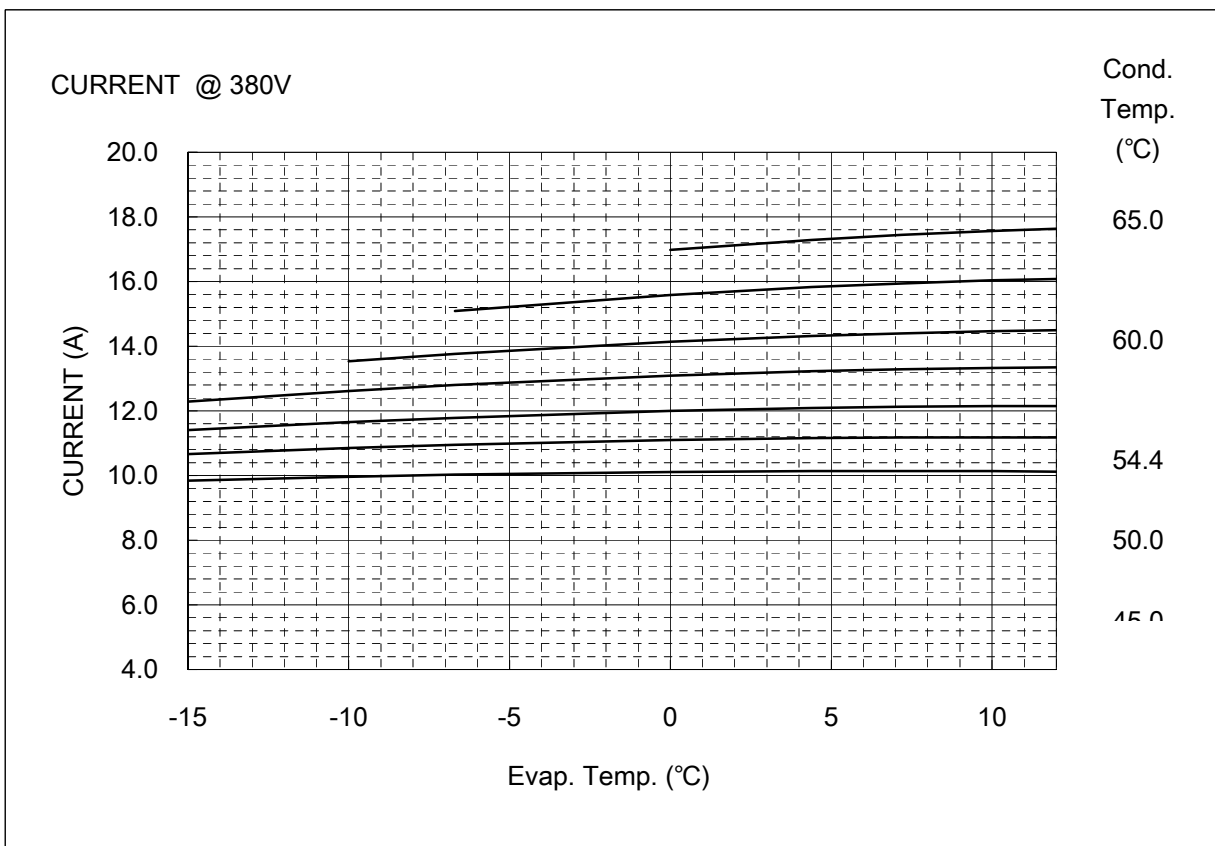
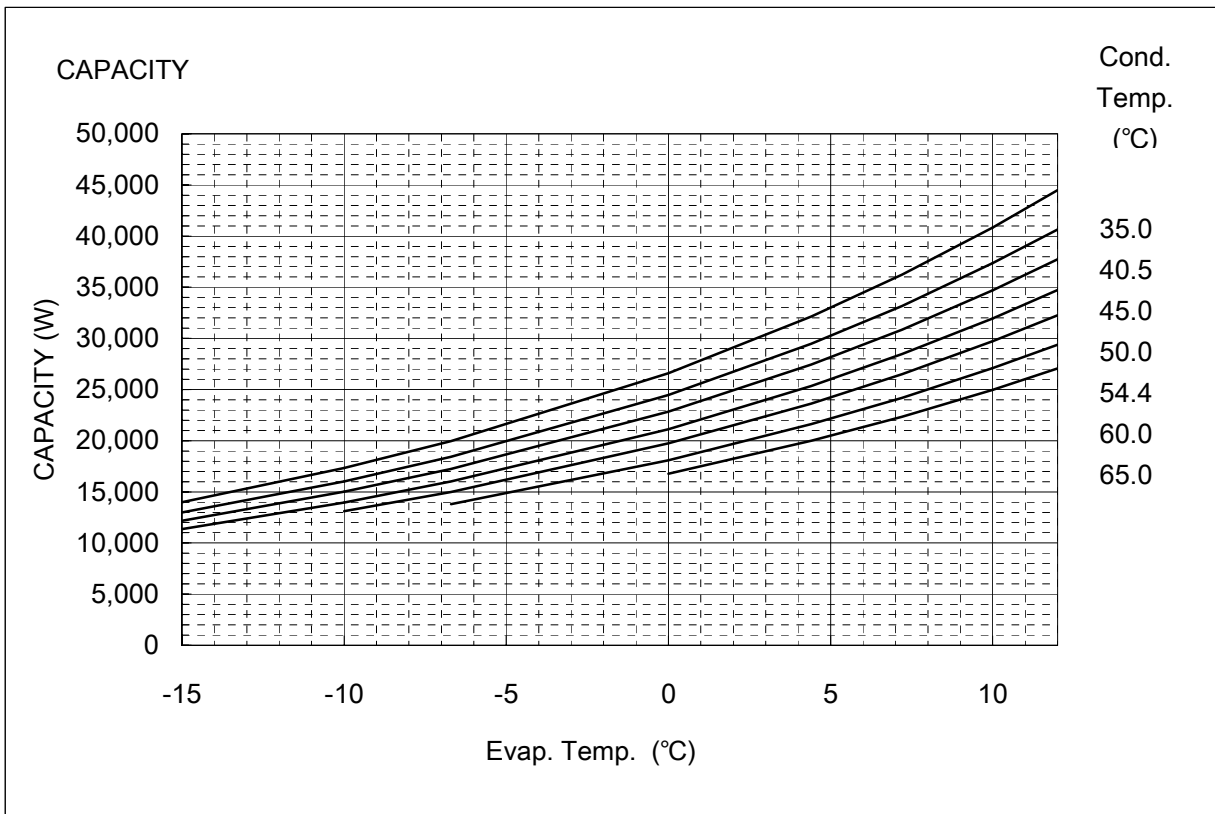

COEFFICIENTS OF PERFORMANCE CURVES



Compressor Model **C-SCN673H8H**
 Power Source **3PH 50Hz 380~415V**
 Suction Gas Superheat (K) **9**
 Sub Cooling (K) **8.3**
 Compressor Cooling **Natural Cooling**
 Refrigerant **R407C**

$$X=C1+C2*(S)+C3*D+C4*(S2)+C5*(S*D)+C6*(D2)+C7*(S3)+C8*(D*S2)+C9*(S*D2) +C10*(D3)$$

X——CAPACITY(W) OR POWER(W) OR CURRENT(A) OR FLOW(kg/h)

S——EVAPORATING TEMP, °C

D——CONDENSING TEMP, °C

380V-50Hz	CAPACITY (W)	POWER (W)	CURRENT (A)
C1	4.385418E+04	3.789742E+03	6.643865E+00
C2	2.086970E+03	8.494227E+00	4.627843E-03
C3	-5.826675E+02	7.607690E-01	2.892567E-02
C4	3.917697E+01	5.315345E-01	9.518885E-04
C5	-3.253378E+01	-7.770154E-01	-1.060762E-03
C6	2.556823E+00	1.521306E+00	2.001702E-03
C7	2.792101E-01	-1.219165E-03	-1.520234E-06
C8	-4.106046E-01	-2.981842E-02	-4.396756E-05
C9	1.643059E-01	2.199506E-02	3.363549E-05
C10	-5.398074E-08	6.932807E-09	2.007584E-12

Note: The polynomial coefficients subject to change without notice.

DIMENSIONAL SKETCH

C-SC Series

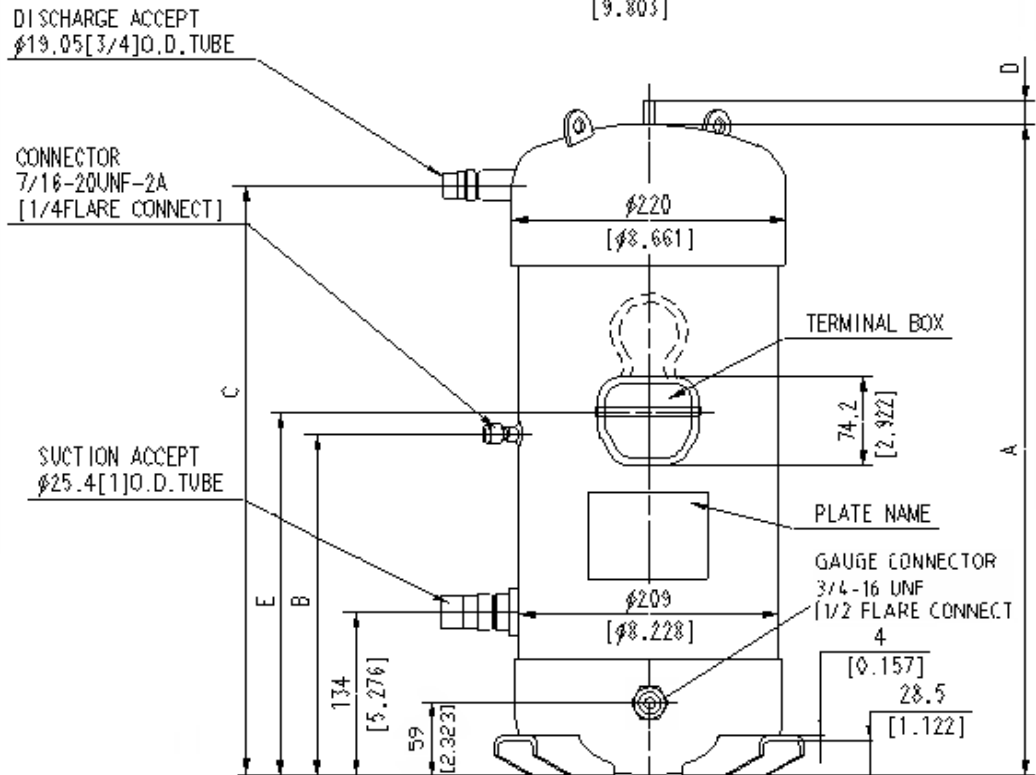
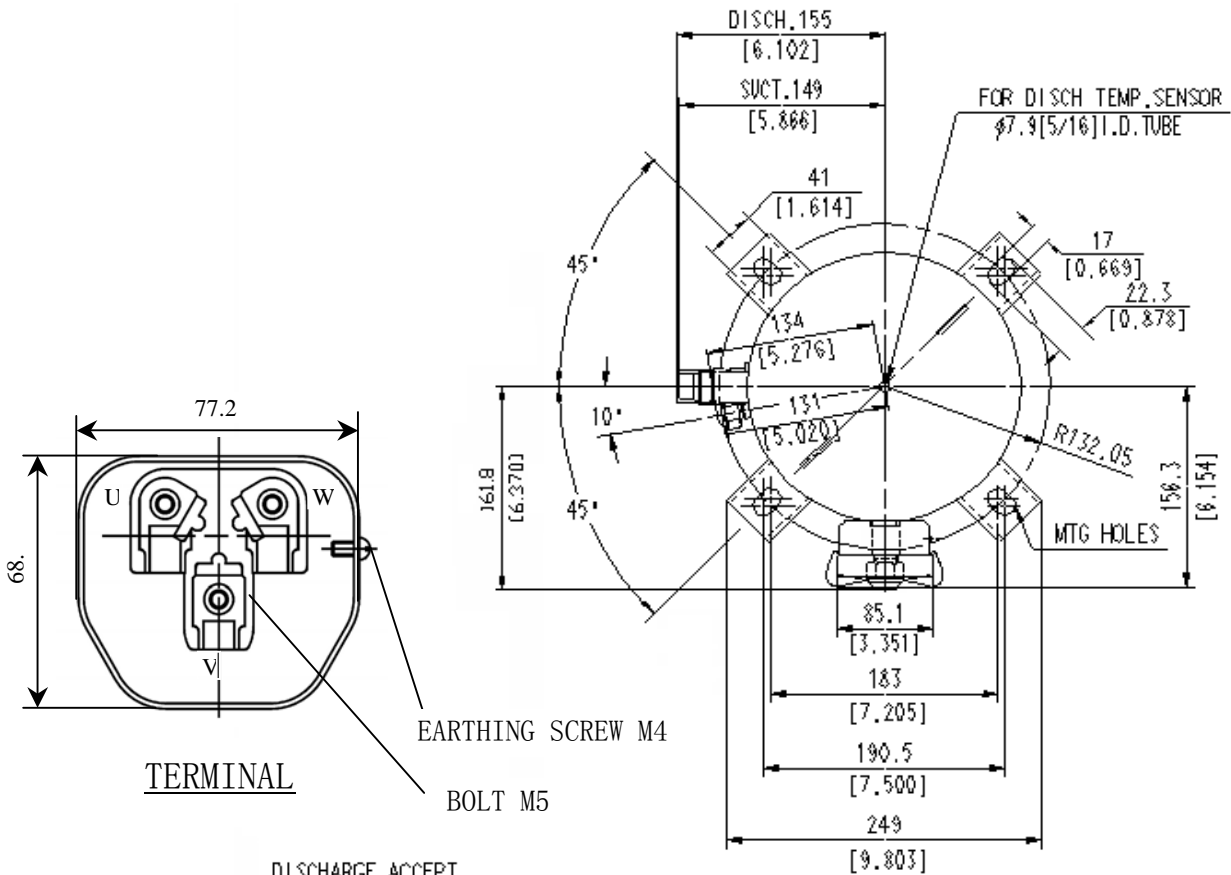

Compressor Code	A	B	C	D
809 *8* 8* (8HP)	538	284	486	8
809 *9* 8* (9HP)				
809 *0* 8*(10HP)	553	299	501	9
809 *2* 8*(12HP)				

WIRING & MOUNTING SKETCH

WIRING DIAGRAM C-SC Series 3phase B8

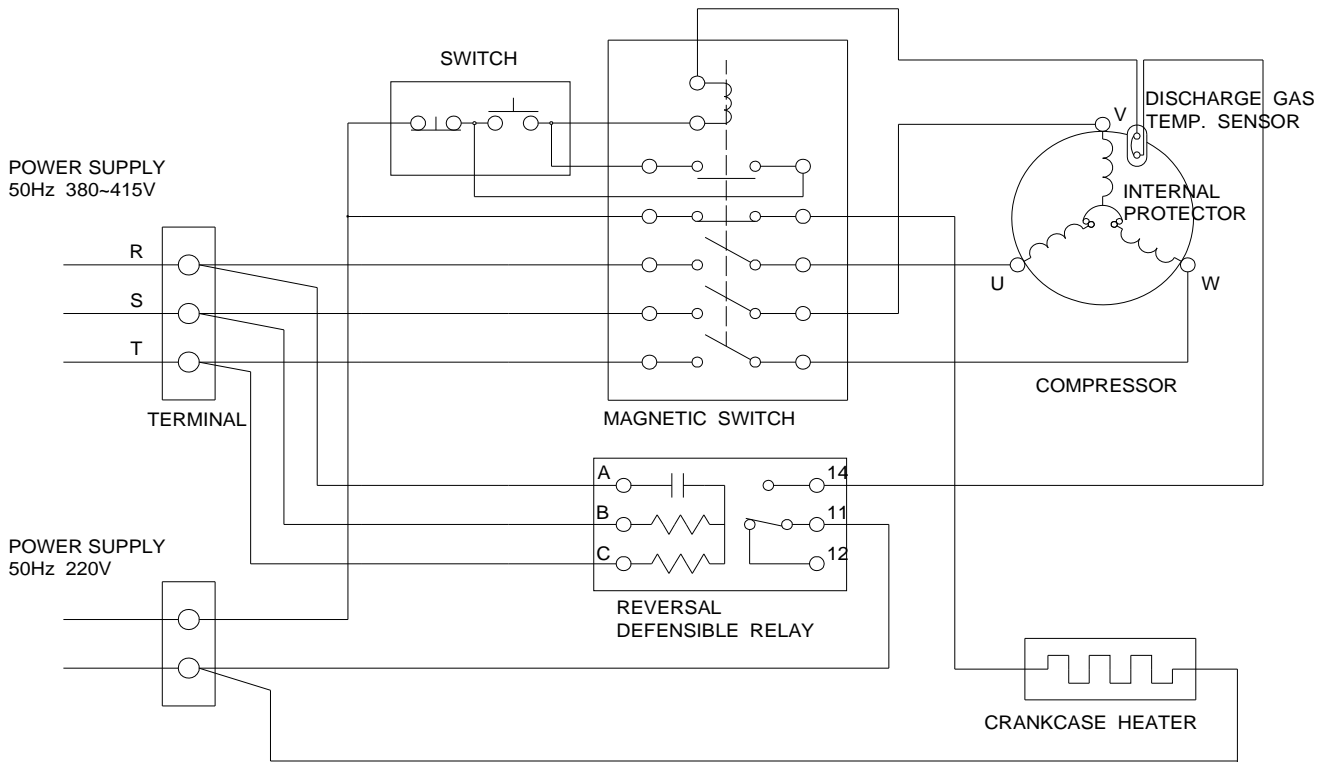

MOUNTING SKETCH

