

Kelvion

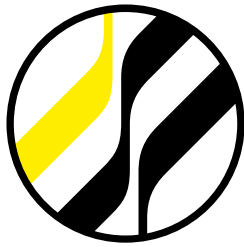

Commercial Air Coolers

Kelvion KSC / KBC

SUPERIOR COOLING FOR COMMERCIAL APPLICATIONS



Kelvion



EXPERTS IN HEAT EXCHANGE – SINCE 1920

Welcome to Kelvion! Where Heat Exchange is our Business. We are one of the leading global manufacturers of heat exchangers and have been providing solutions for almost every industrial application imaginable since the 1920s, specializing in customized solutions suitable for extreme environmental conditions - as of 2015 under the name of Kelvion.

With one of the most extensive selections of heat exchangers in the world, we are a well-known partner in many industries, including transportation, energy, oil and gas, the heavy industry, chemical and marine as well as sugar, food and beverage and the HVAC and refrigeration technology sector. Our products include Compact Fin Heat Exchangers, Plate Heat Exchangers, Single Tube Heat Exchangers, Transformer Cooling Systems, Cooling Towers and Shell & Tube Heat Exchangers.

Our many years of experience and in-depth expertise have made us specialists in this field. Our heat exchangers are designed specifically to meet the needs of the respective machine or equipment system, ensuring outstanding energy efficiency and reliability in any market segment. This gives our customers a cutting-edge over their competitors while also reducing operating costs over the long term.

As your heat exchange partner, we understand that outstanding and reliable after-sales services are critical for you, our customer, and we work alongside with you in close partnership supporting you throughout the full life cycle of your plant and equipment to ensure lasting business success.

Kelvion – Experts in Heat Exchange.

KELVION – A TRIBUTE TO LORD KELVIN (1824 - 1907)



Lord Kelvin formulated the laws of thermodynamics and absolute units of temperature are stated in kelvin, in his honor.

OUR LOGO – INSPIRED FROM THE SCHEMATIC FOR HEAT EXCHANGER

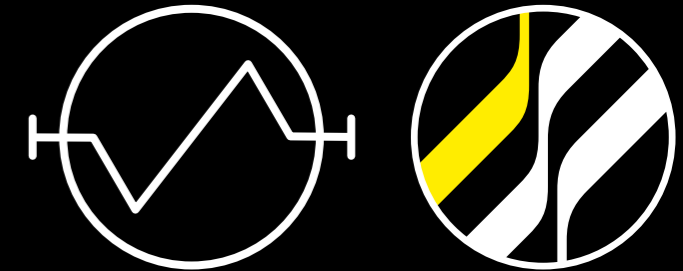

67 BRANCHES AND SALES PARTNERS WORLDWIDE

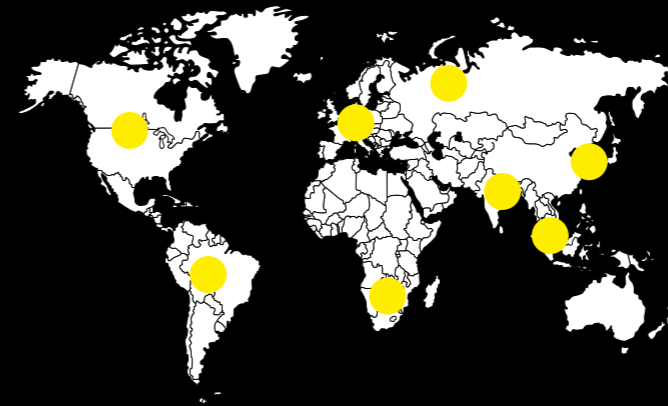

5,000 EMPLOYEES WORLDWIDE

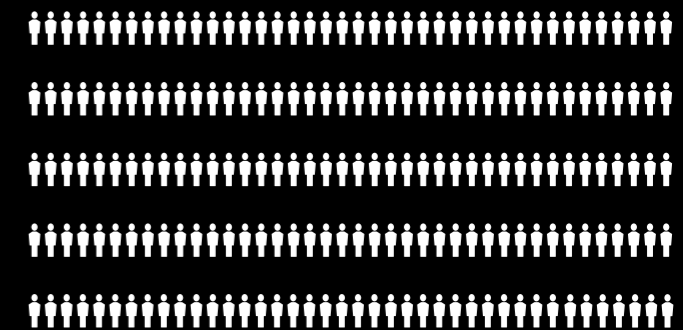

YOUR MARKETS ARE OUR MARKETS

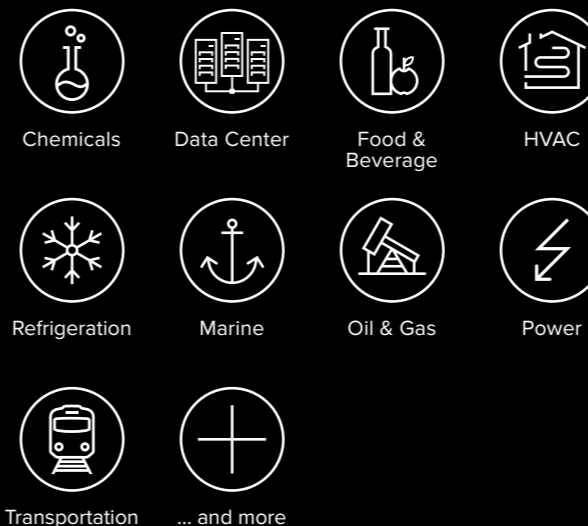

KELVION HAS A LONG HISTORY



SUPERIOR COOLING FOR COMMERCIAL APPLICATIONS



TEMPERATURE RANGE (t_L)

KSC/KBC 23

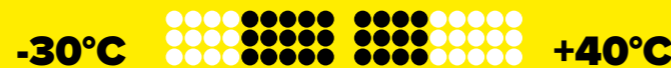

CAPACITY RANGE (for SC2)



TEMPERATURE RANGE (t_L)

KSC/KBC 30

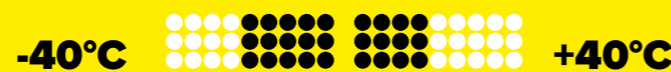

TYPE DESIGNATION CODE

1 2 3 4 5 6 7 8 9

K S C - 30 2 - 4 R N -

- | | | | |
|---|-----------------------|---|------------------------|
| 1 | Size of product | 6 | Number of rows deep |
| 2 | Case style of product | 7 | Fin spacing |
| 3 | Coil block system | 8 | Defrost system |
| 4 | Fan diameter | 9 | Additional information |
| 5 | Number of fans | | |

Refrigerant & max. operating pressure (Box 9)

HX32	HFC 32 bar
GL16	Glycol 16 bar
CX45	CO ₂ 45 bar
CX90	CO ₂ 90 bar

YOUR BENEFITS

- ▶ Kelvion KSC offers you the latest development of our range of commercial air coolers
- ▶ Efficient and competitive solution for basic applications in supermarkets, warehouses or cold stores
- ▶ Side covers, drip tray and inner drip tray are hinged and removable to ensure accessibility during installation or inspection
- ▶ Round corners on casing offers attractive design for easy cleaning
- ▶ Latest generation EC technology with reduced current consumption and a great system performance
- ▶ Pre-wired fans for fast and sure electrical connections
- ▶ 45 / 90 bar CO₂ options available

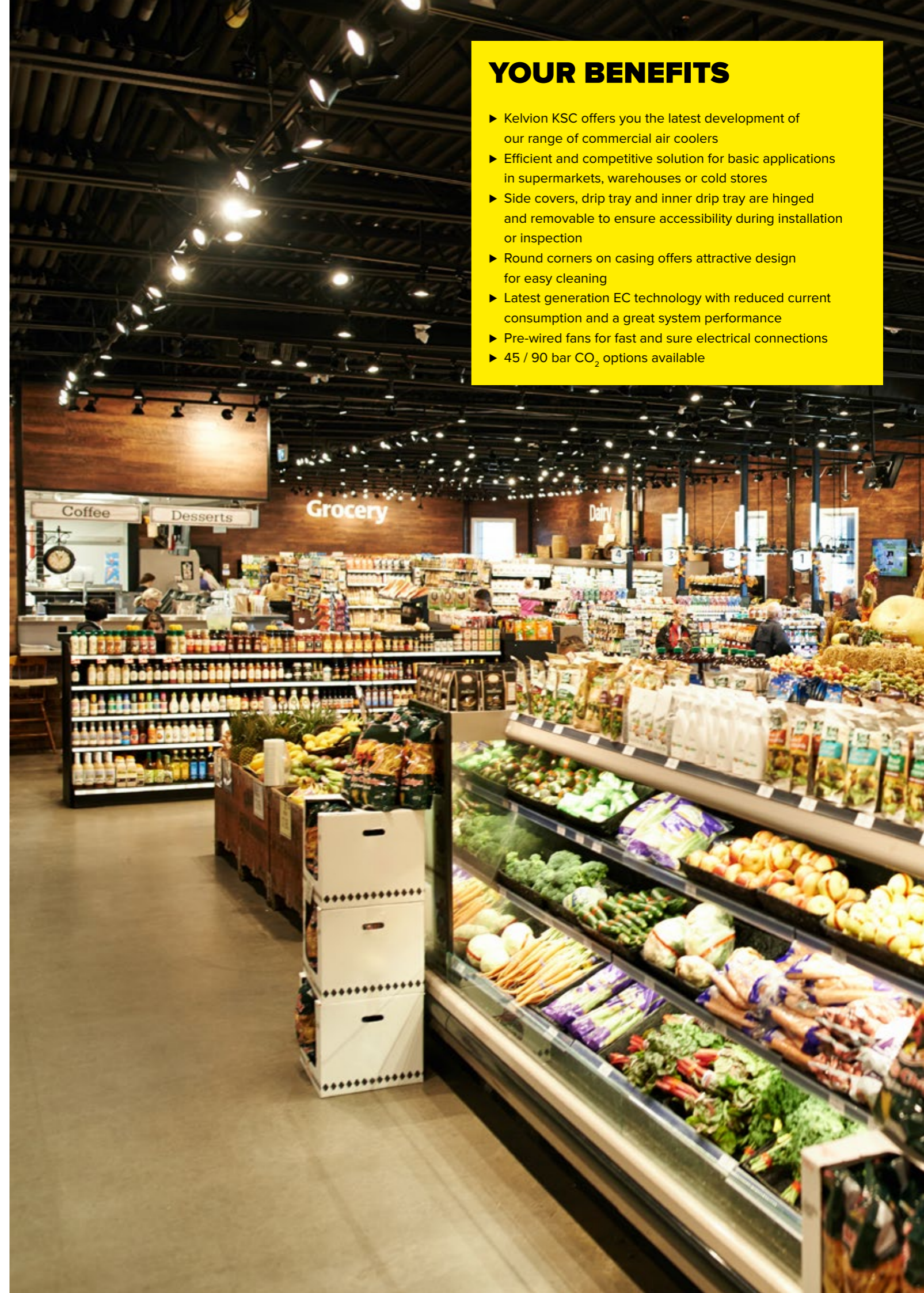

BASIC VERSION

CASING

- ▶ Aluminum
- ▶ Best quality powder coated edges thanks to high-grade powder coating, RAL 9010 pure white
- ▶ Food-safe
- ▶ Easy to clean due to smooth surface and round corners
- ▶ Hinged and removable drip tray (standard construction)
- ▶ Hinged and removable side plates (standard construction)
- ▶ Hinged and removable inner drip tray (standard construction)
- ▶ 3° inclined drip tray for safe condensate drain

ELECTRIC DEFROST

- ▶ Tubular heater: Stainless steel
- ▶ Connections: steam-proof
- ▶ Mains voltage: 1/N/PE 230V 50/60Hz
- ▶ Readily wired for connection box
- ▶ Optimized tubular heater configurations ensure fast and even defrosting
- ▶ Aluminum tube sleeves: Ensure excellent heat transfer to the fins and thus effective defrosting cycles with optimized service life

HEAT EXCHANGER

- ▶ Tube: Copper, inner finned, Ø 12 mm
- ▶ Fins: Aluminum HFE® fins
- ▶ End plates: Aluminum
- ▶ Staggered tube system
- ▶ Fin spacing:
R = 4.0 mm
B = 7.0 mm
- ▶ Fins flared to form-fit the core tube
- ▶ Internal cleanliness according to DIN 14277
- ▶ Connection Inlet: Single injection via copper pipe for solder connection, sealed; Venturi distributor with multiple injection
- ▶ Connection Outlet:
Copper pipe for solder connection with schrader valve UNF 7/16", sealed
- ▶ Delivery with approx. 5 PSI overpressure

FAN UNIT

- ▶ EC technology
- ▶ Axial fan
Draw-through Design >V< KSC
Blow-through Design >A< KBC
- ▶ Fan diameter: 230, 300 (ESM Motor)
- ▶ Permissible motor operating temperatures (50/60 Hz)
D230= -30°C to +50°C
D300= -40°C to +40°C
- ▶ Supply voltage: 1/N/PE 230V 50/60Hz
- ▶ Motor protection: Built-in thermal contact (inaccessible)
- ▶ Protection class:
KS(B)C 23: IP55
KS(B)C 30: IP54
- ▶ Insulation class: B (130°C)
- ▶ Motor Control:

KS(B)C 23- 2 fan speeds

- Ø 230 : Standard 1,600 rpm (Delivery condition)
- Ø 230 : Option C 1,000 rpm

KS(B)C 30- 4 fan speeds

- Ø 300 : Standard 1,600 rpm (Delivery condition)
- Ø 300 : Option A 1,400 rpm
- Ø 300 : Option B 1,200 rpm
- Ø 300 : Option C 1,000 rpm

Speed change according to the circuit diagram by bridging the connection terminals

Please observe the manufacturer's information!

MOTOR LABEL DATA

Type	Standard 50/60Hz 1,600 rpm	
	W	A
KSC 23	32	0,30
KSC 30	85	0,70

Motor data per fan

Data provided by the manufacturer



KSC 30



KBC 30

TECHNICAL DATA KSC / KBC HFC

Fin spacing 4 mm (R) | Sound level S1

Type	Rating Q _o at 50/60 Hz, R404A		Cooling surface	Air flow	Air throw	Tube volume	Connections		Sound	Fans (Operational values at 230±10%V-1 50/60 Hz)				Energy Class	
	SC1	SC2					Inlet	Outlet		L _{wa}	Blade	Per aircooler			R404A
												Ømm	Ømm		
231-2R_	1,9	1,3	4,7	840	7	0,9	10x1.0*	12x1.0	62	230	1.590	34	0,27	B	
231-3R_	2,4	1,6	7,0	790	6	1,3	10x1.0*	12x1.0	62	230	1.590	34	0,27	B	
232-3R_	4,7	3,1	14,0	1.580	9	2,5	10x1.0*	22x1.0	65	230	1.590	68	0,54	B	
233-3R_	7,2	4,8	21,0	2.370	11	3,7	15x1.0**	28x1.5	66	230	1.590	102	0,81	B	
234-3R_	9,4	6,3	28,0	3.160	12	4,9	15x1.0**	28x1.5	68	230	1.590	136	1,08	B	
301-3R_	4,1	2,4	9,7	1.650	9	1,8	10x1.0**	22x1.0	68	300	1.600	79	0,58	C	
301-4R_	4,6	2,9	12,9	1.520	9	2,5	10x1.0*	22x1.0	68	300	1.600	79	0,58	C	
301-6R_	5,2	3,1	19,1	1.380	8	3,6	12x1.0**	22x1.0	68	300	1.600	79	0,58	B	
302-3R_	8,4	5,1	19,4	3.300	13	3,6	15x1.0**	28x1.5	71	300	1.600	158	1,16	C	
302-4R_	9,0	5,5	25,7	3.040	12	4,7	15x1.0**	28x1.5	71	300	1.600	158	1,16	C	
302-6R_	9,9	6,5	38,3	2.760	11	6,9	15x1.0**	28x1.5	71	300	1.600	158	1,16	B	
303-4R_	13,7	8,9	38,6	4.560	15	7,0	15x1.0**	28x1.5	73	300	1.600	237	1,74	B	
303-6R_	15,4	10,0	57,4	4.140	14	10,2	22x1.0**	35x1.5	73	300	1.600	237	1,74	B	
304-4R_	18,1	11,8	51,4	6.080	17	9,1	22x1.0**	35x1.5	74	300	1.600	316	2,32	B	
304-6R_	20,1	13,1	76,5	5.520	16	13,4	22x1.0**	35x1.5	74	300	1.600	316	2,32	B	

TECHNICAL DATA KSC / KBC HFC

Fin spacing 7 mm (B) | Sound level S1

Type	Rating Q _o at 50/60 Hz, R404A		Cooling surface	Air flow	Air throw	Tube volume	Connections		Sound	Fans (Operational values at 230±10%V-1 50/60 Hz)				Energy Class	
	SC2	SC3					Inlet	Outlet		L _{wa}	Blade	Per aircooler			R404A
												Ømm	Ømm		
231-2B_	0,9	0,6	2,8	910	7	0,9	10x1.0*	12x1.0	62	230	1.590	34	0,27	C	
231-3B_	1,2	0,8	4,2	880	7	1,3	10x1.0*	12x1.0	62	230	1.590	34	0,27	B	
232-3B_	2,3	1,7	8,4	1.760	10	2,5	10x1.0*	22x1.0	65	230	1.590	68	0,54	B	
233-3B_	3,5	2,5	12,5	2.640	12	3,7	12x1.0**	28x1.5	66	230	1.590	102	0,81	B	
234-3B_	4,6	3,5	16,7	3.520	14	4,9	15x1.0**	28x1.5	68	230	1.590	136	1,08	B	
301-3B_	1,9	1,2	5,8	1.790	10	1,8	10x1.0*	12x1.0	68	300	1.600	79	0,58	C	
301-4B_	2,2	1,6	7,7	1.750	10	2,5	10x1.0*	22x1.0	68	300	1.600	79	0,58	C	
301-6B_	2,8	2,0	11,4	1.620	9	3,6	12x1.0**	22x1.0	68	300	1.600	79	0,58	B	
302-3B_	3,6	2,6	11,6	3.580	15	3,6	15x1.0**	28x1.5	71	300	1.600	158	1,16	C	
302-4B_	4,4	3,3	15,4	3.500	14	4,7	15x1.0**	28x1.5	71	300	1.600	158	1,16	C	
302-6B_	5,6	4,2	22,9	3.240	13	6,9	15x1.0**	28x1.5	71	300	1.600	158	1,16	B	
303-4B_	7,0	4,8	23,1	5.250	17	7,0	15x1.0**	28x1.5	73	300	1.600	237	1,74	B	
303-6B_	8,7	6,0	34,3	4.860	16	10,2	22x1.0**	35x1.5	73	300	1.600	237	1,74	B	
304-4B_	9,6	6,3	30,7	7.000	20	9,1	22x1.0**	35x1.5	74	300	1.600	316	2,32	B	
304-6B_	11,8	7,7	45,8	6.480	19	13,4	22x1.0**	35x1.5	74	300	1.600	316	2,32	B	

Type	Rating Q _o at 50/60 Hz, R448A MP		Rating Q _o at 50/60 Hz, R449A MP		Rating Q _o at 50/60 Hz, R452A MP		Rating Q _o at 50/60 Hz, R454A MP		Rating Q _o at 50/60 Hz, R455A MP		Rating Q _o at 50/60 Hz, R134A	
	SC1	SC2	SC1	SC2	SC1	SC2	SC1	SC2	SC1	SC2	SC1	SC2
231-2R_	1,7	1,1	1,6	1,0	1,6	1,0	1,6	1,0	1,5	0,8	1,5	1,0
231-3R_	2,2	1,4	2,1	1,3	2,1	1,3	2,1	1,4	1,9	1,1	1,9	1,2
232-3R_	4,8	2,8	4,6	2,7	4,6	3,0	4,7	2,7	4,3	2,3	3,9	2,4
233-3R_	7,2	4,5	6,9	4,3	6,8	4,4	7,0	4,5	6,5	3,8	5,9	3,5
234-3R_	9,6	5,7	9,3	5,5	9,2	6,0	9,3	5,5	8,7	4,6	8,1	4,9
301-3R_	3,6	2,3	3,6	2,3	4,0	2,3	3,8	-	3,6	1,9	3,3	2,1
301-4R_	4,6	2,7	4,6	2,7	4,6	2,8	4,4	-	4,3	2,3	3,9	2,3
301-6R_	5,0	3,3	5,0	3,2	5,3	3,2	5,1	-	5,0	2,8	4,4	2,7
302-3R_	7,3	4,6	7,3	4,6	8,2	4,6	7,7	-	7,1	3,9	6,8	4,3
302-4R_	8,5	5,4	8,5	5,4	8,4	5,4	8,8	-	7,8	4,6	7,8	5,0
302-6R_	10,1	6,6	10,1	6,6	10,0	6,5	10,2	-	9,6	5,7	-	-
303-4R_	14,0	8,6	13,9	8,6	13,7	8,9	13,2	-	13,1	7,7	12,0	7,0
303-6R_	16,1	9,8	16,1	9,8	15,7	10,3	15,3	-	15,5	9,2	13,5	8,1
304-4R_	18,5	11,6	18,5	11,6	18,1	11,7	18,4	-	17,4	10,4	15,8	9,5
304-6R_	21,1	13,5	21,2	13,5	20,6	13,3	20,8	-	20,4	12,5	17,4	10,4

Type	Rating Q _o at 50/60 Hz, R448A MP		Rating Q _o at 50/60 Hz, R449A MP		Rating Q _o at 50/60 Hz, R452A MP		Rating Q _o at 50/60 Hz, R454A MP		Rating Q _o at 50/60 Hz, R455A MP		Rating Q _o at 50/60 Hz, R134A	
	SC2	SC3	SC2	SC3	SC2	SC3	SC2	SC3	SC2	SC3	SC2	SC3
231-2B_	0,7	0,6	0,7	0,5	0,7	0,5	0,7	0,5	0,6	-	0,7	0,5
231-3B_	1,0	0,8	1,0	0,8	1,0	0,8	1,0	0,8	0,8	-	1,0	0,7
232-3B_	2,1	1,6	2,0	1,5	2,0	1,5	2,0	1,5	1,7	-	1,9	1,3
233-3B_	3,2	2,4	3,1	2,3	3,1	2,2	3,1	2,3	2,6	-	2,8	1,9
234-3B_	4,3	3,3	4,1	3,1	4,1	3,1	4,1	3,1	3,4	-	3,9	2,7
301-3B_	1,9	1,2	1,7	1,2	1,8	1,2	-	-	1,4	-	1,5	0,9
301-4B_	2,1	1,6	2,1	1,6	2,1	1,5	-	-	1,8	-	2,0	1,3
301-6B_	2,8	2,1	2,8	2,0	2,7	2,0	-	-	2,3	-	2,5	1,6
302-3B_	3,4	2,6	3,4	2,6	3,4	2,6	-	-	2,8	-	3,3	2,4
302-4B_	4,2	3,2	4,2	3,2	4,2	3,2	-	-	3,5	-	-	-
302-6B_	5,5	4,2	5,5	4,2	5,5	4,2	-	-	4,7	-	-	-
303-4B_	6,5	4,8	6,5	4,8	6,5	4,7	-	-	5,4	-	6,0	3,9
303-6B_	8,4	6,2	8,3	6,2	8,6	5,9	-	-	7,1	-	7,4	4,7
304-4B_	8,6	6,4	8,6	6,4	9,2	6,2	-	-	7,2	-	7,9	5,1
304-6B_	11,1	8,1	11,1	8,0	11,7	7,7	-	-	9,4	-	9,6	5,9

Standard condition t₁ t₂ DT1
 NB1/SC1 +10°C 0°C 10K
 NB2/SC2 0°C -8°C 8K
 * Single injection
 ** Multiple injection via Venturi distributor
 *** Air throw at 0,5m/s
 MP = Mid point
 Multiple injection via CAL - Distributor available as option
 Subject to modification.

Standard condition t₁ t₂ DT1
 NB2/SC2 0°C -8°C 8K
 NB3/SC3 -18°C -25°C 7K
 * Single injection
 ** Multiple injection via Venturi distributor
 *** Air throw at 0,5m/s
 MP = Mid point
 Multiple injection via CAL - Distributor available as option
 Subject to modification.

TECHNICAL DATA **KSC / KBC** CO₂ up to 45bar

Fin spacing 4 mm (R) | Sound level S1

Type	Rating Q ₀ at 50/60 Hz, CO ₂ 45bar		Cooling surface	Air flow	Air throw	Tube volume	Connections 45 bar		Sound
	SC1	SC2					Inlet	Outlet	
KSC/KBC...	kW	kW	m ²	m ³ /h	m	dm ³	Ømm	Ømm	L _{WA} dB(A)
231-2R_	1,8	1,2	4,7	840	7	0,9	10x1.0*	12x1.0	62
231-3R_	2,3	1,5	7,0	790	6	1,3	10x1.0*	12x1.0	62
232-3R_	4,9	3,3	14,0	1580	9	2,5	10x1.0*	12x1.0	65
233-3R_	7,1	4,8	21,0	2370	11	3,7	10x1.0*	12x1.0	66
234-3R_	9,7	6,6	28,0	3160	12	4,9	12x1.0**	18x1.0	68
301-3R_	4,4	3,0	9,7	1650	9	1,8	10x1.0*	12x1.0	68
301-4R_	4,9	3,3	12,9	1520	9	2,5	10x1.0*	12x1.0	68
301-6R_	5,3	3,6	19,1	1380	8	3,6	10x1.0*	12x1.0	68
302-3R_	8,4	5,6	19,4	3300	13	3,6	10x1.0*	12x1.0	71
302-4R_	9,8	6,7	25,7	3040	12	4,7	12x1.0**	18x1.0	71
302-6R_	10,9	7,4	38,3	2760	11	6,9	12x1.0**	18x1.0	71
303-4R_	14,2	9,6	38,6	4560	15	7,0	15x1.0**	18x1.0	73
303-6R_	16,0	10,9	57,4	4140	14	10,2	15x1.0**	18x1.0	73
304-4R_	19,6	13,3	51,4	6080	17	9,1	15x1.0**	18x1.0	74
304-6R_	20,6	13,9	76,5	5520	16	13,4	15x1.0**	18x1.0	74

TECHNICAL DATA **KSC / KBC** CO₂ up to 45bar

Fin spacing 7 mm (B) | Sound level S1

Type	Rating Q ₀ at 50/60 Hz, CO ₂ 45bar		Cooling surface	Air flow	Air throw	Tube volume	Connections 45 bar		Sound
	SC2	SC3					Inlet	Outlet	
KSC/KBC...	kW	kW	m ²	m ³ /h	m	dm ³	Ømm	Ømm	L _{WA} dB(A)
231-2B_	0,8	0,6	4,7	840	7	0,9	10x1.0*	12x1.0	62
231-3B_	1,1	0,8	7,0	790	6	1,3	10x1.0*	12x1.0	62
232-3B_	2,5	1,7	14,0	1580	9	2,5	10x1.0*	12x1.0	65
233-3B_	3,6	2,8	21,0	2370	11	3,7	10x1.0*	12x1.0	66
234-3B_	4,9	3,4	28,0	3160	12	4,9	12x1.0**	18x1.0	68
301-3B_	1,9	1,5	9,7	1650	9	1,8	10x1.0*	12x1.0	68
301-4B_	2,6	1,8	12,9	1520	9	2,5	10x1.0*	12x1.0	68
301-6B_	3,2	2,2	19,1	1380	8	3,6	10x1.0*	12x1.0	68
302-3B_	4,2	3,3	19,4	3300	13	3,6	10x1.0*	12x1.0	71
302-4B_	5,3	3,6	25,7	3040	12	4,7	12x1.0**	18x1.0	71
302-6B_	5,9	4,5	38,3	2760	11	6,9	12x1.0**	18x1.0	71
303-4B_	7,8	6,1	38,6	4560	15	7,0	15x1.0**	18x1.0	73
303-6B_	9,7	6,8	57,4	4140	14	10,2	15x1.0**	18x1.0	73
304-4B_	10,6	7,2	51,4	6080	17	9,1	15x1.0**	18x1.0	74
304-6B_	12,5	9,8	76,5	5520	16	13,4	15x1.0**	18x1.0	74

TECHNICAL DATA **KSC / KBC** CO₂ up to 90bar

Fin spacing 4 mm (R) | Sound level S1

Type	Rating Q ₀ at 50/60 Hz, CO ₂ 90bar		Cooling surface	Air flow	Air throw	Tube volume	Connections 90 bar		Sound
	SC1	SC2					Inlet	Outlet	
KSC/KBC...	kW	kW	m ²	m ³ /h	m	dm ³	Ømm	Ømm	L _{WA} dB(A)
231-2R_	1,8	1,1	4,7	840	7	0,9	12.7x0.85*	12.7x0.85	62
231-3R_	2,2	1,4	7,0	790	6	1,3	12.7x0.85*	12.7x0.85	62
232-3R_	4,4	2,8	14,0	1580	9	2,5	12.7x0.85*	12.7x0.85	65
233-3R_	6,5	4,2	21,0	2370	11	3,7	12.7x0.85*	12.7x0.85	66
234-3R_	8,8	5,7	28,0	3160	12	4,9	12.7x0.85**	19.05x1.30	68
301-3R_	3,9	2,5	9,7	1650	9	1,8	12.7x0.85*	12.7x0.85	68
301-4R_	4,4	2,8	12,9	1520	9	2,5	12.7x0.85*	12.7x0.85	68
301-6R_	4,9	3,2	19,1	1380	8	3,6	12.7x0.85*	12.7x0.85	68
302-3R_	7,7	4,9	19,4	3300	13	3,6	12.7x0.85*	12.7x0.85	71
302-4R_	8,8	5,7	25,7	3040	12	4,7	12.7x0.85**	19.05x1.30	71
302-6R_	10,0	6,6	38,3	2760	11	6,9	12.7x0.85**	19.05x1.30	71
303-4R_	13,0	8,5	38,6	4560	15	7,0	12.7x0.85**	19.05x1.30	73
303-6R_	14,8	9,8	57,4	4140	14	10,2	12.7x0.85**	19.05x1.30	73
304-4R_	17,5	11,4	51,4	6080	17	9,1	12.7x0.85**	19.05x1.30	74
304-6R_	19,5	12,9	76,5	5520	16	13,4	15.87x1.05**	19.05x1.30	74

TECHNICAL DATA **KSC / KBC** CO₂ up to 90bar

Fin spacing 7 mm (B) | Sound level S1

Type	Rating Q ₀ at 50/60 Hz, CO ₂ 90bar		Cooling surface	Air flow	Air throw	Tube volume	Connections 90 bar		Sound
	SC2	SC3					Inlet	Outlet	
KSC/KBC...	kW	kW	m ²	m ³ /h	m	dm ³	Ømm	Ømm	L _{WA} dB(A)
231-2B_	0,8	0,6	4,7	840	7	0,9	12.7x0.85*	12.7x0.85	62
231-3B_	1,1	0,8	7,0	790	6	1,3	12.7x0.85*	12.7x0.85	62
232-3B_	2,1	1,6	14,0	1580	9	2,5	12.7x0.85*	12.7x0.85	65
233-3B_	3,2	2,4	21,0	2370	11	3,7	12.7x0.85*	12.7x0.85	66
234-3B_	4,3	3,2	28,0	3160	12	4,9	12.7x0.85**	19.05x1.30	68
301-3B_	1,9	1,3	9,7	1650	9	1,8	12.7x0.85*	12.7x0.85	68
301-4B_	2,3	1,7	12,9	1520	9	2,5	12.7x0.85*	12.7x0.85	68
301-6B_	2,8	2,1	19,1	1380	8	3,6	12.7x0.85*	12.7x0.85	68
302-3B_	3,7	2,7	19,4	3300	13	3,6	12.7x0.85*	12.7x0.85	71
302-4B_	4,5	3,3	25,7	3040	12	4,7	12.7x0.85**	19.05x1.30	71
302-6B_	5,7	4,2	38,3	2760	11	6,9	12.7x0.85**	19.05x1.30	71
303-4B_	6,8	5,0	38,6	4560	15	7,0	12.7x0.85**	19.05x1.30	73
303-6B_	8,5	6,4	57,4	4140	14	10,2	12.7x0.85**	19.05x1.30	73
304-4B_	9,1	6,7	51,4	6080	17	9,1	12.7x0.85**	19.05x1.30	74
304-6B_	11,3	8,5	76,5	5520	16	13,4	15.87x1.05**	19.05x1.30	74

Standard condition t₁ t₀ DT1
 NB1/SC1 +10°C 0°C 10K
 NB2/SC2 0°C -8°C 8K
 * Single injection
 ** Multiple injection via Venturi distributor
 *** Air throw at 0,5m/s

Subject to modification.

Standard condition t₁ t₀ DT1
 NB2/SC2 0°C -8°C 8K
 NB3/SC3 -18°C -25°C 7K
 * Single injection
 ** Multiple injection via Venturi distributor
 *** Air throw at 0,5m/s

Subject to modification.

DIMENSIONS, WEIGHTS, ELECTRIC DEFROST

Kelvion KSC

Type	Dimensions										Electrical defrost 230 V-1 / 400 V-3-Y			Empty Weight (net)		Empty Weight (gross)		Drain D
	H	B	T	L	E ₁	E ₂	E ₃	F	A	W _{min}	Coil	Tray	Total	N	E	N	E	
	mm	mm	mm	mm	mm	mm	mm	mm	mm	mm	kW	kW	kW	kg	kg	kg	kg	inch
231-2	339	760	403	360	480	-	-	140	62	200	0,5	0,5	1,0	9	11	13	15	G 3/4 "
231-3	339	760	403	360	480	-	-	140	62	200	0,5	0,5	1,0	11	12	15	16	G 3/4 "
232-3	339	1.210	403	360	930	-	-	140	62	200	0,9	0,9	1,7	17	19	22	24	G 3/4 "
233-3	339	1.660	403	360	1.380	450	-	140	62	200	1,1	1,1	2,3	24	27	67	70	G 3/4 "
234-3	339	2.110	403	360	1.830	900	-	140	62	200	1,5	1,5	3,0	31	34	82	85	G 3/4 "
301-3	418	810	453	430	530	-	-	140	42	200	1,1	0,5	1,6	15	16	20	21	G 3/4 "
301-4	418	810	453	430	530	-	-	140	42	200	1,1	0,5	1,6	16	18	21	23	G 3/4 "
301-6	418	810	453	430	530	-	-	140	42	200	1,6	0,5	2,1	19	22	24	27	G 3/4 "
302-3	418	1.310	453	430	1.030	-	-	140	42	200	1,8	0,9	2,8	24	27	29	32	G 3/4 "
302-4	418	1.310	453	430	1.030	-	-	140	42	200	1,8	0,9	2,8	28	30	33	35	G 3/4 "
302-6	418	1.310	453	430	1.030	-	-	140	42	200	2,8	0,9	3,7	34	37	39	42	G 3/4 "
303-4	418	1.810	453	430	1.530	500	-	140	42	200	2,6	1,3	3,9	39	42	86	89	G 1 1/4 "
303-6	418	1.810	453	430	1.530	500	-	140	42	200	3,9	1,3	5,2	48	53	95	100	G 1 1/4 "
304-4	418	2.310	453	430	2.030	1.000	-	140	42	200	3,4	1,7	5,1	50	54	105	109	G 1 1/4 "
304-6	418	2.310	453	430	2.030	1.000	-	140	42	200	5,1	1,7	6,7	62	68	117	123	G 1 1/4 "

Kelvion KBC

Type	Dimensions										Electrical defrost 230 V-1 / 400 V-3-Y			Empty Weight (net)		Empty Weight (gross)		Drain D
	H	B	T	L	E ₁	E ₂	E ₃	F	A	W _{min}	Coil	Tray	Total	N	E	N	E	
	mm	mm	mm	mm	mm	mm	mm	mm	mm	mm	kW	kW	kW	kg	kg	kg	kg	inch
231-2	347	760	346	360	480	-	-	140	62	200	0,5	0,5	1,0	9	11	13	15	G 3/4 "
231-3	347	760	346	360	480	-	-	140	62	200	0,5	0,5	1,0	11	12	15	16	G 3/4 "
232-3	347	1.210	346	360	930	-	-	140	62	200	0,9	0,9	1,7	17	19	22	24	G 3/4 "
233-3	347	1.660	346	360	1.380	450	-	140	62	200	1,1	1,1	2,3	24	27	67	70	G 3/4 "
234-3	347	2.110	346	360	1.830	900	-	140	62	200	1,5	1,5	3,0	31	34	82	85	G 3/4 "
301-3	423	810	450	430	530	-	-	140	42	200	1,1	0,5	1,6	15	16	20	21	G 3/4 "
301-4	423	810	450	430	530	-	-	140	42	200	1,1	0,5	1,6	16	18	21	23	G 3/4 "
301-6	423	810	450	430	530	-	-	140	42	200	1,6	0,5	2,1	19	22	24	27	G 3/4 "
302-3	423	1.310	450	430	1.030	-	-	140	42	200	1,8	0,9	2,8	24	27	29	32	G 3/4 "
302-4	423	1.310	450	430	1.030	-	-	140	42	200	1,8	0,9	2,8	28	30	33	35	G 3/4 "
302-6	423	1.310	450	430	1.030	-	-	140	42	200	2,8	0,9	3,7	34	37	39	42	G 3/4 "
303-4	423	1.810	450	430	1.530	500	-	140	42	200	2,6	1,3	3,9	39	42	86	89	G 1 1/4 "
303-6	423	1.810	450	430	1.530	500	-	140	42	200	3,9	1,3	5,2	48	53	95	100	G 1 1/4 "
304-4	423	2.310	450	430	2.030	1.000	-	140	42	200	3,4	1,7	5,1	50	54	105	109	G 1 1/4 "
304-6	423	2.310	450	430	2.030	1.000	-	140	42	200	5,1	1,7	6,7	62	68	117	123	G 1 1/4 "

DIMENSIONAL DRAWINGS

Kelvion KSC

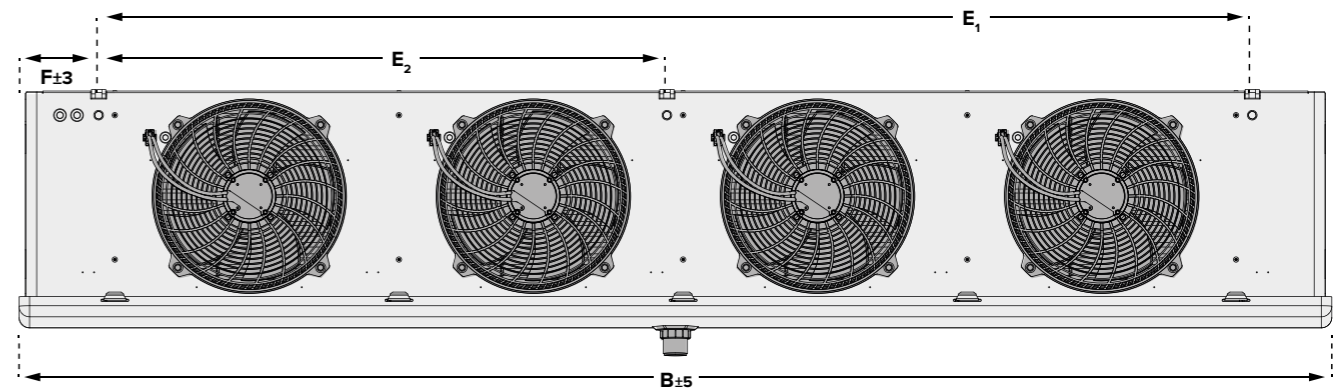
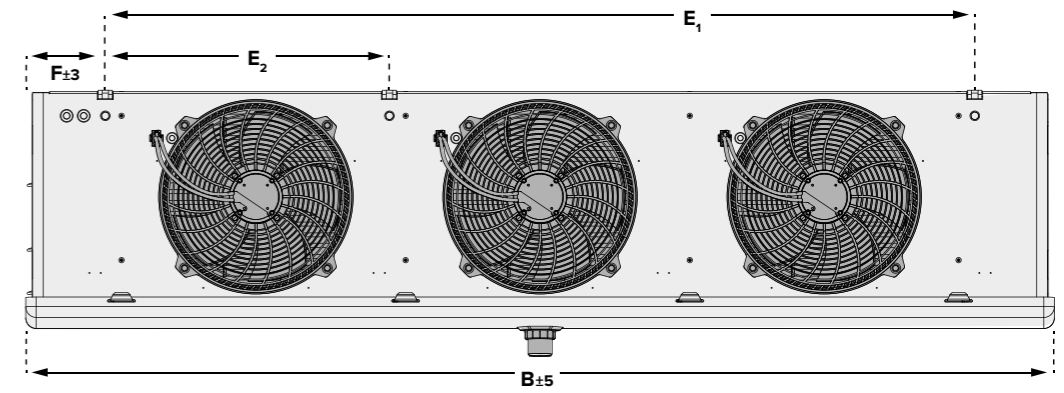
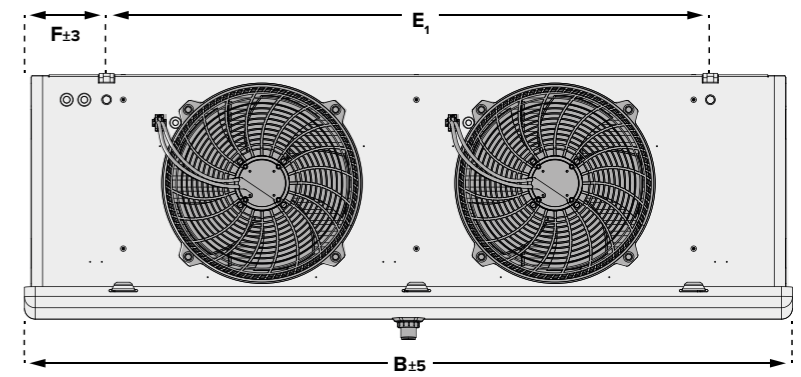
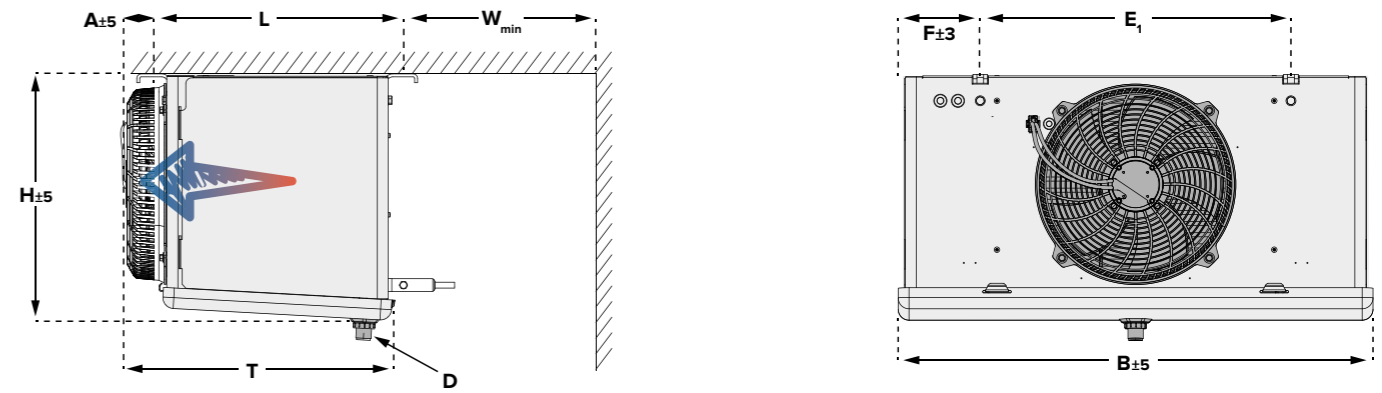

The dimensions are only valid for the standard model design!
Note the differences in dimension among versions and accessories.

VARIANTS

CASING - VARIANTS

DOUBLE-WALLED, INSULATED DRIP TRAY

Prevents condensed water from forming on the bottom side of the pan, and it reduces the transfer of defrost heat into the cold rooms.

The following dimensions are changed:

- Width B: +60 mm
- Height H: +30 mm
- Depth T: +60 mm

FANS HINGED

For easy inspection and cleaning

MOTOR - VARIANT

EC FAN WITH CONTROLLABLE SPEED

Controllable fan
Only available for KSC 30

PROTECTION AGAINST CORROSION

CORROSION PROTECTION 1

- Tubing: Copper
- Fins: Aluminum, epoxy-resin-coated
- End plates: Aluminum protective coating
- Casing: Aluminum/zinc coated steel, protective coating on both sides

CORROSION PROTECTION 4

- Tubing: Copper
- Fins: Aluminum, epoxy-resin-coated
- End plates: Aluminum
- Casing: Aluminum/zinc coated steel, protective coating on on one side

CORROSION PROTECTION 2 - ON REQUEST

- Tubing: Stainless steel (V2A)
- Fins: Aluminum, epoxy-resin-coated
- End plates: Stainless steel
- Casing: Al/zinc coated steel, prot. coating on both sides

CORROSION PROTECTION 3 - ON REQUEST

- Tubing: Stainless steel (V2A)
- Fins: Aluminum
- End plates: Aluminum
- Casing: Al/zinc coated steel, prot. coating on one side

DEFROST - VARIANTS

HOT-GAS COIL IN THE DRIP TRAY (CU)

Hot-gas connection on both sides; copper

HOT GAS IN HEAT EXCHANGER

Hot gas circuit for coil, without non-return valve

DISTRIBUTOR - VARIANT

CAL-DISTRIBUTOR

Multiple injection via CAL

WATER / BRINE

SMALL AND LARGE NUMBER OF DISTRIBUTIONS

up to 16 bar operating pressure

CO₂ - VARIANTS

CO₂ - DIRECT EXPANSION 45 BAR

up to 45 bar operating pressure

CO₂ - DIRECT EXPANSION 90 BAR

up to 90 bar operating pressure

VARIANT OVERVIEW

Variant Name	Available for	Old Variant #	New Variant #
Double insulated drip tray	all	V3.09	053.3
Fans hinged	KSC	V3.10	051.2
Protection against corrosion 1	KS(B)C	V6.01	014.1
Protection against corrosion 2	KS(B)D	V6.02	014.2
Protection against corrosion 3	KS(B)D	V6.03	-
Protection against corrosion 4	KS(B)C	V6.04	011.2
Hot Gas Cu (Drip Tray)	KS(B)C	V4.01	032.2
	KS(B)C	V4.01	033.3
Hot Gas Cu (Coil)*	KS(B)C	V6.05	032.6
CO ₂ 45 bar	all	V7.45	010.15
CO ₂ 90 bar	KS(B)C	V7.90	010.20
Water/Brine	all	V2.xx	010.3
CAL-Distributor	KS(B)C	V6.22	012.2
Fan Controllable Speed	all Ø300	V1.52	070.5

ACCESSORIES

SHUT-UP® (+ADAPTER)

The Shut-Up® optimises the defrosting procedure, especially in deep-freeze applications. Shut-Up® is suspended over the fan unit, closing the Air Cooler. Hot air cannot escape.

Construction:

High-tech microfiber, tearproof, UV-resistant, form- and temperature resistant, rot-proof, food-safe, washable at 30°C, chemical purification P

Selection table & Dimensions:

Type	Kelvion KSC			Shut-Up®	
	Fan blade Ø mm	Connections Ø mm	Fixture Ø mm	Air outlet Ø mm	Length mm
KSC 23	230	253	258	149	390
KSC 30	300	348	358	254	490

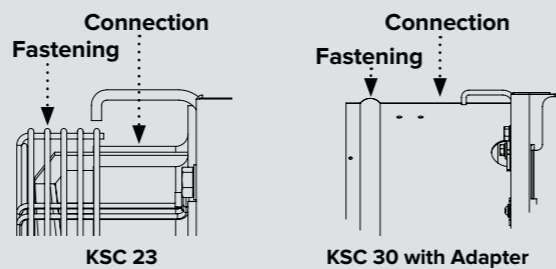
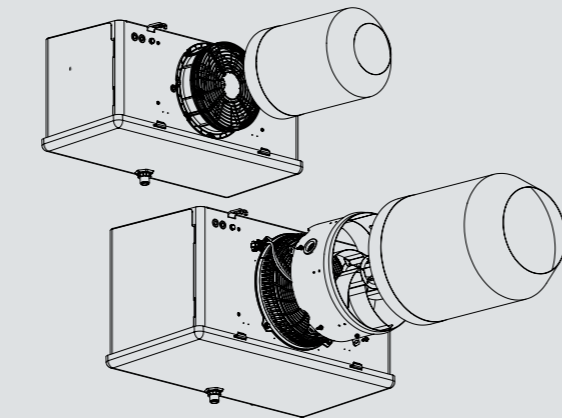

NOTE:

Due to the additional external pressure, the air quantity and Air Cooler capacity change: With using Shut-Up®: Air volume reduces by 10% (-5% cooling capacity) 1 Shut-Up® per fan unit required. Delivery not mounted. For KSC 23, you do not need an additional to install a Shut-Up®.

AIR HOSES (MUST BE PROVIDED ON SITE)

Ventilation can be optimised with textile / PVC air hoses.

- ▶ Applications in work rooms and production areas
- ▶ Cooled goods that are sensitive to draft (i.e. flowers, ripening cheeses)

Advantages:

The air hoses make uniform air distribution possible at very low air speeds.

- ▶ Working in a draft-free environment yields low illness rates
- ▶ Maximum protection for sensitive cooled goods
- ▶ No condensation water: temperatures do not fall below the dew point because air can penetrate the woven material

Dimensions (Connection):

Type	Kelvion KSC		
	Fan blade Ø mm	Connections Ø mm	Fixture Ø mm
KSC 23	230	253	258
KSC 30	300	348	358

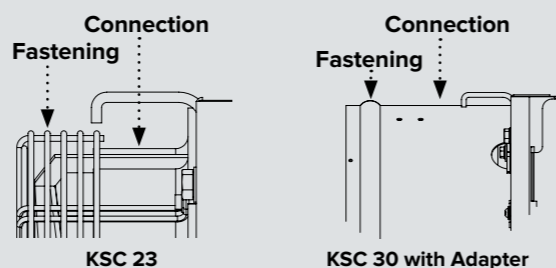

FINNED-TUBE HEATERS KSHR/SHR Z

For air coolers with draw-through fans.
For conditioning of room air.

- ▶ KSHR = Standard design
- ▶ SHR Z = Additional heater
- ▶ KSHR + SHR Z = Greater heating capacity

Selection table, Technical data & Dimensions:

Type	Description	Current				Capacity			
		L1 A	L2 A	L3 A	Total A	L1 kW	L2 kW	L3 kW	Total kW
KSC 23	KSHR 23	4.3	-	-	4.3	1.0	-	-	1.0
KSC 30	KSHR 30	7.6	-	-	7.6	1.7	-	-	1.7
KSC 23	KSHR + SHR 23 Z	4.3	4.3	-	8.6	1.0	1.0	-	2.0
KSC 30	KSHR + SHR 30 Z	7.6	7.6	-	15.1	1.7	1.7	-	3.5

Dimensions:

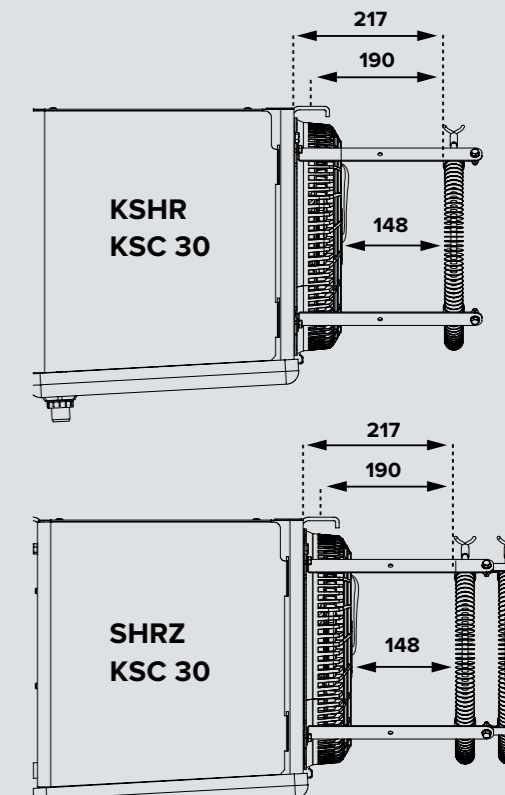
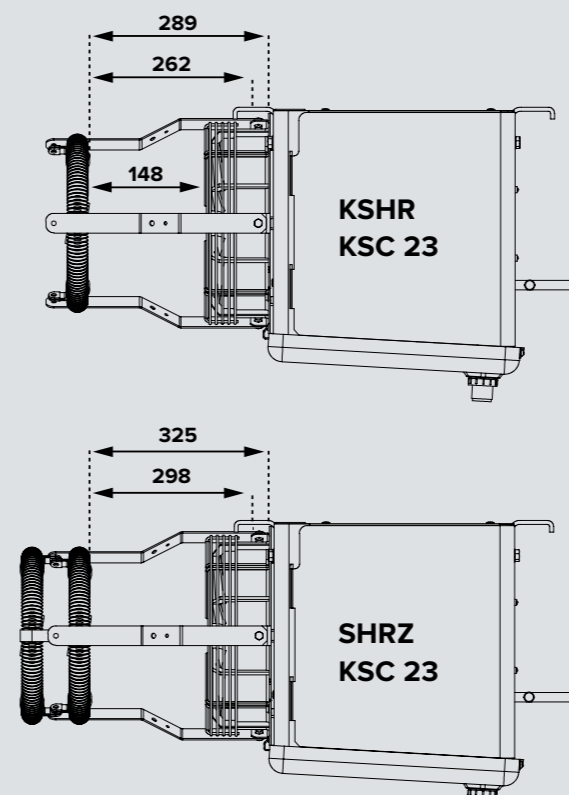

NOTE:

This unit is operated only when the air-cooler fans are in use, to prevent overheating of the ceiling of the cold room. Be sure to observe the relevant safety instructions. 1 KSHR/Z per fan unit required.

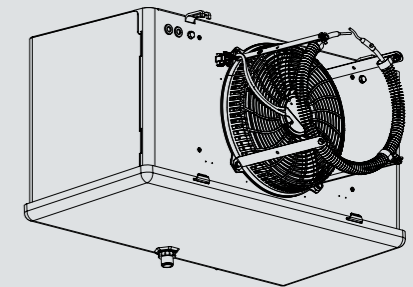

KSHR

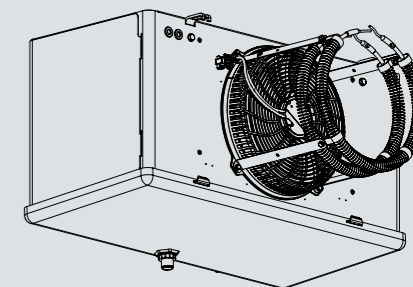

SHR Z

Kelvion Select RT

SELECTION SOFTWARE



- ▶ Kelvion's latest user-friendly, web-based and mobile RT application
- ▶ Select the right components from our extensive product range
- ▶ Receive all information, technical specifications and calculation results
- ▶ Technical data available as pdf-file or as shared Kelvion code
- ▶ Available in several languages and suitable for all operating conditions

www.kelvion.com

www.kelvion.com