



Compressor racks controller

XC642C

Operating manual



CONTENT

1.	GENERAL WARNING	3
1.1	 Please read before using this manual	3
1.2	 Safety Precautions	3
2.	GENERAL DESCRIPRION	3
3.	FIRST INSTALLATION	3
3.1	How to select the gas type	4
3.2	How to set the range of the pressure probes	4
3.3	How to set the kind of display: relative or absolute pressure	4
4.	USER INTERFACE	5
4.1	Displaying	5
4.2	Keyboard	5
4.3	Icons	6
5.	HOW TO SEE AND MODIFY THE SET POINT	6
5.1	How to see the set point of compressors	6
5.2	How to modify the set point of compressors	6
6.	PARAMETERS PROGRAMMING	7
6.1	How to enter the "Pr1" parameter list	7
6.2	How to enter in parameters list "Pr2"	7
6.3	How to change parameter values	7
7.	HOW TO DISABLED AN OUTPUT	7
7.1	How to disabled an output during a maintenance session.	7
7.2	Output disabled signalling.	8
7.3	Regulation with some outputs disabled.	8
8.	RUNNING HOURS OF LOADS	8
8.1	How to display the running hours of a load.	8
8.2	How to reset the running hours of a load.	8
9.	ALARM MENU	8
9.1	How to see the alarms	8
10.	USE OF THE PROGRAMMING "HOT KEY "	9
10.1	How to program a hot key from the instrument (UPLOAD)	9
10.2	How to program an instrument using a hot key (DOWNLOAD)	9
11.	KEYBOARD LOCKING	9
11.1	How to lock the keyboard	9
11.2	To unlock the keyboard	9
12.	LIST OF PARAMETERS	10
12.1	Plant dimensioning and type of regulation.	10
12.2	Others inputs configuration	10
12.3	Display and Measurement unit	11
12.4	Compressors regulation	11
12.5	Liquid injection thermostat (Term. 25-26)	11
12.6	Alarms – compressor section	11
12.7	Other	12
13.	CAPACITY VARIATION WITH SCREW COMPRESSORS	12
14.	THERMOSTAT FOR LIQUID INJECTION	13
15.	TYPE OF REGULATION	13
15.1	NEUTRAL ZONE	13
15.2	PROPORTIONAL BAND	14
16.	MOUNTING & INSTALLATION	15
17.	ELECTRICAL CONNECTIONS	15
17.1	Probes connection	16

18.	RS485 SERIAL LINK	16
19.	TECHNICAL FEATURES	16
20.	ALARMS LIST	16
20.1	Types of alarms and signalling managed	16
20.2	Alarm muting	18
20.3	Alarm conditions – summary table	18
21.	WIRING CONNECTIONS	20
22.	PARAMETERS – DEFAULT VALUES	20

1. General warning

1.1 PLEASE READ BEFORE USING THIS MANUAL

- This manual is part of the product and should be kept near the instrument for easy and quick reference.
- The instrument shall not be used for purposes different from those described hereunder. It cannot be used as a safety device.
- Check the application limits before proceeding.

1.2 SAFETY PRECAUTIONS

- Check the supply voltage is correct before connecting the instrument.
- Do not expose to water or moisture: use the controller only within the operating limits avoiding sudden temperature changes with high atmospheric humidity to prevent formation of condensation
- Warning: disconnect all electrical connections before any kind of maintenance.
- Fit the probe where it is not accessible by the End User. The instrument must not be opened.
- In case of failure or faulty operation send the instrument back to the distributor or to “Dixell S.p.a.” (see address) with a detailed description of the fault.
- Consider the maximum current which can be applied to each relay (see Technical Data).
- Ensure that the wires for probes, loads and the power supply are separated and far enough from each other, without crossing or intertwining.
- In case of applications in industrial environments, the use of mains filters (our mod. FT1) in parallel with inductive loads could be useful.

2. General Description

The **XC642C** is a controller for screw compressor racks, the main objective of controller is to hold the controlled variable at constant value, this function is performed via compressor power control.

The controller survey the pression via 2 pression probe with 4÷20mA current output, while the regulation type is ON/OFF.

Alternatively you can use NTC or PTC temperature probes. The pression data are converted to correspondent gas temperature value according to tables that are stored into controller.

The alarms management is performed by an alarm input for every user. The programming procedure is simplified by HOT KEY use. The communication is performed via ModBus RTU protocol.

3. First Installation

At first installation, it's necessary the following:

1. **Select the kind of gas.**
2. **Set the range of the pressure probes.**

In the following paragraph a short cut for the above operations.

Chapters 3.1 How to select the gas type and 3.2 How to set the range of the pressure probes will show in detail these operations.

3.1 HOW TO SELECT THE GAS TYPE

The controller has memorised the relation between temperature and pressure for some gases.

Default gas is: r404.

If another gas is used, act as in the following:

1. Enter the Programming mode by pressing the **Set** and **DOWN** key for 3s.
2. Select the "**Pr2**" parameter. Then enter the password 3 -2 1.
3. Select the **FtyP, kind of gas**, parameter.
4. Press the "**SET**" key: the value of the parameter will start blinking.
5. Use "**UP**" or "**DOWN**" to change the gas amount the following: . Select the gas among the following: **r22= R22; r404=R404A; 507=R507; 134=134; r717= ammonia.**
6. Press "**SET**" to store the new value and move to the following parameter.

To exit: Press **SET + UP** or wait 30s without pressing a key.

NOTE: the set value is stored even when the procedure is exited by waiting the time-out to expire.

3.2 HOW TO SET THE RANGE OF THE PRESSURE PROBES

If a instrument with the following part number is used: XC642C – xxxxF, it is pre-set to work with pressure probe with the following range:

Code	Range
XC642C – xxxxA opp. xxxxE	-0.5 ÷11 bar (relative pressure)
XC642C – xxxxB	0÷30 bar (relative pressure)

If the probes you're using have a different range act as in the following:

To set the pressure range of the **Probe 1** use the parameter::

PA04: Adjustment of read out corresponding to 4mA

PA20: Adjustment of read out corresponding to 20mA

Practically these parameters has to be set with the start and end scale of the probe range.

WARNING: set a value correspondent to **absolute pressure**. If the transducer measures relative pressure increase the range of 1 bar.

E.I. PP11 relative pressure transducer, range -0.5÷11.0 bar. PA04=0.50; PA20=12.00.

PP30 relative pressure transducer, range: 0÷30bar. PA04=1.00; PA20=31.00.

How to do:

1. Enter the Programming mode by pressing the **Set** and **DOWN** key for 3s.
2. Select the "**Pr2**" parameter. Then enter the password 3 -2 1.
3. Select the **PA04, adjustment of read out corresponding to 4mA**, parameter.
4. Press the "**SET**" key: the value of the parameter will start blinking.
5. Set the lower value of the probe range (lower value +1 if the probe detects relative pressure).
6. Push the **SET** key to confirm the value. The **PA20: adjustment of read out corresponding to 20mA** parameter will be displayed.
7. Set the higher value of the range (higher value +1 if the probe detects relative pressure).
8. Push the **SET** key to confirm the value. Next parameter will be displayed.

3.3 HOW TO SET THE KIND OF DISPLAY: RELATIVE OR ABSOLUTE PRESSURE

After setting the probe range by means of the PA04, PA20, parameters, it's possible to select if the absolute or relative pressure has to be displayed.

The controller is pre-set for RELATIVE PRESSURE displaying.

If the **absolute pressure** has to be displayed, act as in the following:

1. Enter the Programming mode by pressing the **Set** and **DOWN** key for 3s.
2. Select the "Pr2" parameter. Then enter the password **3 - 2 - 1**.
3. Select by pushing the **UP** key the **rELP** parameter.
4. Push the **SET** to modify the value.
5. Set the **AbS** value and push the **SET** key to confirm it.

To exit: Press **SET + UP** or wait 30s without pressing a key.

4. User Interface



4.1 DISPLAYING

UPPER DISPLAY	LOWER DISPLAY	ICONS
Temperature	Pressure	- Working loads - Measurement unit - Alarm or status Icons

4.2 KEYBOARD

SET To see or modify the set point. in programming mode it selects a parameter or confirm an operation.

Alarm menu: By holding it pressed for **3s**, the current alarm is erased.

▲ (UP) To enter the Alarm menu.

In programming mode: it browses the parameter codes or increases the displayed value.

With Hot key inserted: it starts the Hot key programming procedure.

▼ (DOWN) **In programming mode:** it browses the parameter codes or decreases the displayed value.

Manual restart of loads: By holding it pressed for **3s**, it switches on again loads previous locked by a safety digital input alarm.

CLOCK To display the loads running hours.

By holding it pressed for 3s the **Maintaining menu** is entered.





KEY COMBINATIONS

▲ + ▼ To lock and unlock the keyboard.

SET + ▼ To enter the programming mode.

SET + ▲ To exit the programming mode.

4.3 ICONS

LED	FUNCTION	MEANING
°C	ON	Celsius degrees
°F	ON	Fahrenheit degrees
bar	ON	bar displaying
PSI	ON	PSI displaying
1	ON	Load 1 on
1	Flashing	Load 1 is waiting to start (1HZ). or digital input alarm for Load 1 (2Hz). o Load 1 in maintenance status (2Hz).
2	ON	Load 2 on
2	Flashing	Load 2 is waiting to start (1HZ). or digital input alarm for Load 2 (2Hz). o Load 2 in maintenance status (2Hz).
3	ON	Load 3 on
3	Flashing	Load 3 is waiting to start (1HZ). or digital input alarm for Load 3 (2Hz). o Load 3 in maintenance status (2Hz).
4	ON	Load 4 on
4	Flashing	Load 4 is waiting to start (1HZ). or digital input alarm for Load 4 (2Hz). o Load 4 in maintenance status (2Hz).
	ON	The Maintenance menu has been entered
	Flashing	One or more loads have been placed in maintenance status
	ON	Alarm is happening
	ON	All the stored alarms have been seen.
	Flashing	A new alarm has happened

5. How to see and modify the set point

5.1 HOW TO SEE THE SET POINT OF COMPRESSORS

 restart

prg



reset



- 1) Push and release the **SET** key;
- 2) The Lower display will show the “**SEtC**” label, will the Upper display will show its value.

To exit: push the **SET** key or wait for 30 without pressing any keys.

5.2 HOW TO MODIFY THE SET POINT OF COMPRESSORS

WARNING: before setting the target set points for the first time, check and, if necessary, modify the type of freon (par. FtyP) and the default unit of measurement (par. dEU) for compressors and fans

PROCEDURE

1. Set the kind of freon by means of the FtyP parameter (see chapter 3.1 How to select the gas type)
2. Set the measurement unit (dEU par.).
3. Check and if necessary modify the set point limits (LSE and HSE par.).

 restart

prg



reset



1. Push the **SET** key for more than 2 seconds;
2. The Lower display will show the “**SEtC**” label, will the Upper display will show its value flashing.
3. To change the Set value push the **▲** or **▼** within 30s.
4. To memorise the new value and pass to the fan set point push the **SET** key.

5. To change its value push the **▲** or **▼** within 30s.

To exit: push the **SET** key or wait for 30 without pressing any keys.

6. Parameters programming

6.1 HOW TO ENTER THE "Pr1" PARAMETER LIST

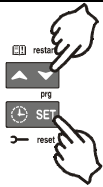

To enter the "Pr1" parameter list, user accessible, operate as follows:

1. Hold pressed the **SET** and **DOWN** key for 3s.
2. The controller displays the name of the parameter in the Lower display, its value on the Upper display.
3. Press the **"SET"** key: the value of the parameter will start blinking.
4. Use **"UP"** or **"DOWN"** to change the value.
5. Press **"SET"** to store the new value and move to the following parameter.

To exit: Press **SET + UP** or wait 30s without pressing a key.

NOTE: the set value is stored even when the procedure is exited by waiting the time-out to expire.

6.2 HOW TO ENTER IN PARAMETERS LIST "Pr2"

The "Pr2" parameter list is protected by a security code (Password).

SECURITY CODE is 321

To access parameters in "Pr2":

1. Enter the "Pr1" level.
2. Select "Pr2" parameter and press the **"SET"** key.
3. The flashing value "0 --" is displayed.
4. Use **▲** or **▼** to input the security code and confirm the figure by pressing **"SET"** key.
5. Repeat operations 2 and 3 for the other digits.

NOTE: each parameter in "Pr2" can be removed or put into "Pr1" (user level) by pressing **"SET"** + **▼**. When a parameter is present also in "Pr1" decimal point of the lower display is on.

6.3 HOW TO CHANGE PARAMETER VALUES

1. Enter the Programming mode.
2. Select the required parameter with **▲** or **▼**.
3. Press the **"SET"** key the value start blinking.
4. Use **▲** or **▼** to change its value.
5. Press **"SET"** to store the new value and move to the following parameter.

To exit: Press **SET + UP** or wait 15s without pressing a key.

NOTE: the new programming is stored even when the procedure is exited by waiting the time-out.

7. How to disabled an output

To disabled an output during a maintenance session means to exclude the output from the regulation.

7.1 HOW TO DISABLED AN OUTPUT DURING A MAINTENANCE SESSION.



1. Push the **CLOCK** key for 3s.
2. The LED's of the first output is switched on, the Lower display shows the **"StA"** label, while the Upper display shows the **"On"** label

if the first output is enabled, or the **"oFF"** label if the output is disabled for a maintenance section. With compressor with more steps all the LED's linked to the compressor and the valves are switched on..

3. Select the output by pressing the **UP** or **DOWN** key.

4. **To modify the status of the output:** push the **SET** key, the status of the output starts flashing, then push the UP or DOWN to pass from “On” to “OFF” and viceversa.
5. Push the **SET** key to confirm the status and pass to the next output..

To exit: push the **CLOCK** key or wait 30 sec

7.2 OUTPUT DISABLED SIGNALLING.

If an output is disabled its led blinks (2 Hz)

7.3 REGULATION WITH SOME OUTPUTS DISABLED.

If some outputs are disabled they don't take part to the regulation, so the regulation goes on with the other outputs.

8. Running hours of loads

8.1 HOW TO DISPLAY THE RUNNING HOURS OF A LOAD.

The controller memorises the running hours of each load.



To see how long a load has been working follow this procedure:

1. Press and release the “CLOCK” key.
2. The led of the first output is switched on, the **Upper Display** shows the “**HUR**” label, while the **Lower Display** shows the running hours of the first output.
3. To see the running hours of the following load press the UP key .

To exit: push the **CLOCK** key or wait 30 sec

8.2 HOW TO RESET THE RUNNING HOURS OF A LOAD.

1. Display the running hour according to the above procedure.
2. Select the load by pressing the UP key.
3. Push the **SET** key (immediately on the lower display the **rSt** label is displayed).
4. Hold pushed the key for some seconds till the “**rSt**” label starts flashing and the lower display shows zero.

To exit: push the **CLOCK** key or wait 30 sec

NOTE: if the **SET** key is released within 2s, the controller reverts to display the running hours of the selected loads.

9. Alarm Menu

The controller memorises the last 20 alarms happened, together with their duration..

To see the alarm codes see par. **par. 20** Alarms list.

9.1 HOW TO SEE THE ALARMS



1. Push the ▲ key.
2. The last alarm happened is showed on the Upper display, while the lower display shows its number.
3. Push again the ▲ key and the other alarm are displayed starting from the most recent.

4. To see the alarm **duration** and push the **SET** key.
5. By pushing again the ▲ **or SET** key the next alarm is displayed.

Alarms erasing.

1. Enter the Alarm Menu.

- To erase the displayed alarm push the "SET" key till the "rSt" label will be displayed in the Lower Display. **NOTE** the running alarms cannot be erased..
- To erase the whole Alarm Menu, hold pressed the "SET" key for 10s.

10. Use of the programming "HOT KEY "

10.1 HOW TO PROGRAM A HOT KEY FROM THE INSTRUMENT (UPLOAD)

- Program one controller with the front keypad.
- When the controller is ON, insert the "**Hot key**" and push \blacktriangle key; the "**uPL**" message appears followed a by flashing "**End**"
- Push "**SET**" key and the **End** will stop flashing.
- Turn OFF the instrument remove the "**Hot Key**", then turn it ON again.

NOTE: the "Err" message is displayed for failed programming. In this case push again \blacktriangle key if you want to restart the upload again or remove the "**Hot key**" to abort the operation.

10.2 HOW TO PROGRAM AN INSTRUMENT USING A HOT KEY (DOWNLOAD)

- Turn OFF the instrument.
- Insert a **programmed "Hot Key" into the 5 PIN receptacle** and then turn the Controller ON.
- Automatically the parameter list of the "**Hot Key**" is downloaded into the Controller memory, the "**doL**" message is blinking followed a by flashing "**End**".
- After 10 seconds the instrument will restart working with the new parameters.
- Remove the "**Hot Key**".

NOTE the message "Err" is displayed for failed programming. In this case turn the unit off and then on if you want to restart the download again or remove the "**Hot key**" to abort the operation.
The unit can UPLOAD or DOWNLOAD the parameter list from its own E2 internal memory to the "**Hot Key**" and vice-versa.

11. Keyboard locking

11.1 HOW TO LOCK THE KEYBOARD

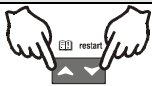

- Keep the \blacktriangle and \blacktriangledown keys pressed together for more than 3 s the \blacktriangle and \blacktriangledown keys.
- The "POF" message will be displayed and the keyboard is locked. At this point it is only possible to view the set point or enter the HACCP menu.

11.2 TO UNLOCK THE KEYBOARD

Keep the \blacktriangle and \blacktriangledown keys pressed together for more than 3s till the "**POn**" flashing message appears.

12. List of parameters

12.1 PLANT DIMENSIONING AND TYPE OF REGULATION.

oA1, oA2, oA3, oA4, oA4 Outputs 1- 4 configuration: by means of these parameters the plant can be dimensioned according to the number and type of compressors and/or fans and the number of steps for each one.

Each relay according to the configuration of the oA(i) parameter can work as:

- **Compressor:** oAi = cPr,
- **Step:** oAi = StP
- **Injection liquid valve:** oAi = Lin
- **Alarm:** oAi = ALr
- **Not used:** oAi = nu

NOTE: also the "FAn" value is present. This value **must not** be used..

COMPRESSORS CONFIGURATION

The regulation is **always** performed by the **P1** Probe.

With **step compressors** the output of compressor has to be set before the output of the step.

ES. Compressor with 3 steps: **oA1 = cPr, oA2= StP, oA2 = StP.**

If an oAi set as step without any previous oAi set as cPr the configuration alarm "CSStP" will be activated.

StP: **valve outputs polarity:** polarity of the outputs for capacity valves. It determines the state of the relays associated with the capacity valves (only for homogeneous and stepped-capacity compressors):

- oP**=valve enabled with open contact;
- cL**= valve enabled with closed contact.

FtyP: **Freon Type:** set the kind of freon used in the plant

r22 = R22; r404= R404A ; 507= R507; 134=134; r717=r717 (ammonia)

rTy: **Type of regulation (see par.15): db = neutral zone, Pb = proportional band.**

Sty Activation: type of sequence

YES = rotation: this algorithm distributes the working time between the various loads to ensure even run times.

no = fixed sequence: the compressors are enabled and disabled in fixed sequence: first, second etc.

12.1.1 Probe 1 configuration

Pbc: **Probe 1 setting.** Cur = $4 \div 20$ mA probe; ntc = NTC probe, Ptc = NTC probe.

PA04: **Adjustment of read out for the Probe 1** (used only if Pbc=Cur), corresponding to **4mA** input signal, given by the suction probe ($0 \div 31$ bar or $0 \div 450$ PSI or $0 \div 3100$ KPA)

Warning: set a value correspondent to absolute pressure. If the transducer measures relative pressure increase the range of 1 bar.

See also par. 3.2 How to set the range of the pressure probes

Ex. **PP11** relative pressure transducer, range $-0.5 \div 12.0$ bar. PA04=0.5 ($-0.5 \div 1$); PA20=12.0 ($1 \div 1$).

PP30 relative pressure transducer, range: $0 \div 30$ bar. PA04=1; PA20=31.

PA20: **Adjustment of read out for the Probe 1** corresponding to **20mA** input signal, given by the suction probe ($0 \div 31.0$ bar or $0 \div 450$ PSI or $0 \div 3100$ KPA)) **SEE THE WARNING FOR PA04.**

CAL: **Probe 1 calibration** ($-12.0 \div 12.0$ bar; $-12.0 \div 12.0$ °C or $-20 \div 20$ PSI/°F)

FcAL: **Probe 2 calibration** ($-12.0 \div 12.0$ bar; $-12.0 \div 12.0$ °C or $-20 \div 20$ PSI/°F)

12.2 OTHERS INPUTS CONFIGURATION

SEP: **Polarity of Low pressure-switch alarm** (terminals 9-10)

oP =alarm with open contacts; **cL**= alarm with closed contact

HPP: **Polarity of High pressure-switch alarm** (terminals HP)

oP = alarm with open contacts; **cL**= alarm with closed contact

i1c **Configurable digital input polarity** (terminals 3-4):

oP: the digital input is activated by opening the contact;

CL: the digital input is activated by closing the contact.

i1F **Configurable digital input polarity functions** (terminals 3 - 4)

ES = Energy saving; oFF = instrument shut down; LLI = liquid level alarm

did Configurable digital input delay: (enabled only if i1F=LL) 0÷255min

ALIP: Alarm input for compressors and fans polarity
oP: the digital input is activated by opening the contact;
CL: the digital input is activated by closing the contact.

ALMr Manual reset of alarms for compressors and fans.

no = automatic recover of alarm: regulation restart when the correspondent digital input is disabled
yES = manual recover for the alarms of compressors.

12.3 DISPLAY AND MEASUREMENT UNIT

dEU: Default measurement unit for displaying (bar=bar; °C=°C, PSI=PSI; °F=°F)

NOTE1: The dEU parameter sets the measurement unit also for the set point and the following parameters: CAL, FCAL, Pbd, ESC, LSE, HSE, Pb, ESF, LSF, HSF, LAL, HA, LAF, HAF.

rES Resolution for °C and bar (in = integer; dE= decimal point)

rELP Pressure displaying: AbS = absolute pressure; rEL = relative pressure.

NOTE: In this case the pressure displayed, the set point and the following parameters LSE and HSE, LSF and HSF are automatically decreased by 1.0 bar or 14 PSI

12.4 COMPRESSORS REGULATION

Pbd: Proportional band or neutral zone width (0.10÷5.00bar/0.5÷30°C or 1÷80PSI/1÷50°F)

The band (or zone) is symmetrical compared to the target set point, with extremes: set+Pbd/2 ... set-Pbd/2. The measurement unit depends on the dEU par.

ESC Energy saving value for compressors: (-20÷20bar; -50÷50°C) this value is add to the compressor set point.

onon: Minimum time between 2 following switching ON of the same compressor (0÷255 min).

oFon: Minimum time between the switching off of a compressor and the following switching on. (0÷255min). *Note: usually onon is greater than oFon.*

don: Time delay between the insertion of two different compressors (0÷99.5min; res. 10s).

doF: Time delay between switching off of two different compressors (0÷99.5 min; res. 10s)

donF: Minimum time a stage stays switched ON (0÷99.5 min; res. 10s)

FdLy: "don" delay enabled also for the first call. If enabled, the triggering of the step is delayed for a "don" value, respect to the call. (no = "don" not enabled; yES="don" enabled)

FdLF "doF" delay enabled also for the first switching off. It enables the "doF" delay between the request of a release and the actual switching off. (no = "doF" not enabled; yES="doF" enabled)

odo: Regulation delay on start-up: (0÷255s) on switching ON the instrument starts working after the time delay imposed in this parameter.

LSE: Minimum set point: The measurement unit depends on dEU parameter. It sets the minimum value that can be used for the set point, to prevent the end user from setting incorrect values.

HSE: Maximum set point: The measurement unit depends on dEU parameter. It sets the maximum acceptable value for set point.

12.5 LIQUID INJECTION THERMOSTAT (TERM. 25-26)

Lit: Set point (°C) for liquid injection thermostat (0 ÷ 150°C)

Lid: Differential for liquid injection thermostat (0.1 ÷ 10.0)

12.6 ALARMS – COMPRESSOR SECTION

PAo: Alarm probe exclusion at power on. it is the period starting from instrument switch on, before an alarm probe is signalled. (0÷255 min). During this time if the pressure is out of range all the compressor are switched on.

LAL: Low pressure (temperature) alarm – compressor section: The measurement unit depends on dEU parameter. It's always subtracted to the set point. When the value SET-LAL is reached the A03C alarm is enabled, (possibly after the tAo delay time).

HAL: High pressure (temperature) alarm– compressor section: The measurement unit depends on dEU parameter. It's always added to the set point. When the value SET+HAL is reached the A04C alarm is enabled, (possibly after the tAo delay time).

tAo: Low and High pressure (temperature) alarms delay– compressor section: (0÷255 min) time interval between the detection of a pressure (temperature) alarm condition and alarm signalling.

- Ser:** **Service request:** (1÷9990 hours, res. 10h) number of running hours after that the "A14" maintenance call is generated.
- PEn:** **Low pressure-switch intervention numbers:** (0÷15). If the low pressure-switch is enabled PEn times in the PEI interval, the controller is locked. **Only the manually unlocking is possible.** Every time the pressure-switch is enabled all the compressor are turned off.
- PEI:** **Pressure-switch interventions time** (0÷15 min) Interval, linked to the PEn parameter, for counting interventions of the low pressure-switch..
- SPr:** **number of steps engaged with faulty probe.** (0÷#compr).
- PnF:** **High pressure-switch intervention numbers:** (0÷15 with 0 the manually unlocking is disabled) if the high pressure-switch is enabled PnF times in the PiF interval, the controller is locked. **It can be unlocked only manually.** Every time the pressure-switch is enabled all the compressors are turned off and all the fans are turned on.
- PIF:** **Pressure-switch interventions time** (1÷15 min) Interval, linked to the PEn parameter, for counting interventions of the high pressure-switch..

12.7 OTHER

- tbA** **Alarm relay silencing:** by pushing one of the keypad buttons. **no**= alarm relay stays on; **yES**= alarm relay is switched off by pushing any keys.
- oFF** **Switching ON/OFF enabling from keyboard:** (**no** = disabled; **yES**= enabled) It permits the switching ON/OFF of the instrument by pressing the SET key for more than 4s.
- Ad1:** **Compressors address** (1 –247) It is used in monitoring system.
- rEL** **Software release** for internal use.
- Ptb** **Parameter table code:** readable only.
- Pr2** **Protected parameters list**

13. Capacity variation with screw compressors

Screw compressors have an their own algorithm to change the capacity engaged.

As for the step compressors, the opening of the valves changes the capacity of compressors. The difference is given from the number of valves engaged. Screw compressors have always 1 valve or no valves engaged. The following tables shows how the capacities changes according to the opening and closing of the valves for screw compressor with 4 steps, with StP=cL valves work with voltage or StPP=oP: valves work without voltage.

However the kind of regulation depends on the **rty** parameter, while the number of step depends on the setting of the oA2, oA3, oA4 parameters.

StP = cL: valve active when energised

Capacity %	Compressor Relay (15-17)	Valve 1(25%) Relay (16-19)	Valve 2 (50%) Relay (18-21)	Valve 3 (75%) Relay (20-22)
25%	CLOSED	CLOSED	OPEN	OPEN
50%	CLOSED	OPEN	CLOSED	OPEN
75%	CLOSED	OPEN	OPEN	CLOSED
100%	CLOSED	OPEN	OPEN	OPEN

StPP = oP valve active when energised

Capacity %	Compressor Relay (15-17)	Valve 1(25%) Relay (16-19)	Valve 2 (50%) Relay (18-21)	Valve 3 (75%) Relay (20-22)
25%	CLOSED	OPEN	CLOSED	CLOSED
50%	CLOSED	CLOSED	OPEN	CLOSED
75%	CLOSED	CLOSED	CLOSED	OPEN
100%	CLOSED	CLOSED	CLOSED	CLOSED

14. Thermostat for liquid injection

The second probe (term. 4-7), is used to detect the temperature of the head of compressor and inject cooling liquid when the temperature is too high. The 5th relay (25-26) is designed for this purpose.

Parameters involved are: **Lit: Set point (°C) for liquid injection thermostat** (0 ÷ 150.0)

Lid: Differential for liquid injection thermostat (0.1 ÷ 10.0)

15. Type of regulation

15.1 NEUTRAL ZONE

This kind of regulation is available only for compressors. The neutral zone (Pbd) is symmetrical compared to the target set point, with extremes: $\text{set} + \text{Pbd}/2$... $\text{set} - \text{Pbd}/2$. If the pressure (temperature) is inside this zone the controller maintains the same number of loads switched on and off, without changing anything.

When the pressure (temperature) go out from the zone, regulation starts. If the pressure is greater than $\text{SET} + \text{Pbd}/2$, the loads are switching on with timing given by parameters: don and doF.

A load is turned on only if the his safety times **onon**, **oFon**, **donF** are over.

Regulation stops when the pressure (temperature) come back into the neutral zone.

In the following a simplify exemplum that explains the regulation in neutral zone for compressor homogeneous with 1 step for each compressors. The safety times onon, oFon and donF are not considered. In the real regulation the a load is entered or turned off only if these times are over.

Ex. Neutral zone control

oA1 = cMP; oA2 = StP; oA3 = StP; oA4 = nu

rty = db neutral zone regulation

FdLy = no

"don" delay not enabled at first calling after an equilibrium condition.

dLF = no

"doF" delay not enabled at first calling after an equilibrium condition.

	Relay 1 - Compressor	Relay valve 1 (33%)	Relay valve 1 (66%)
33%	ON	ON	OFF
66%	ON	OFF	ON
100%	ON	OFF	OFF

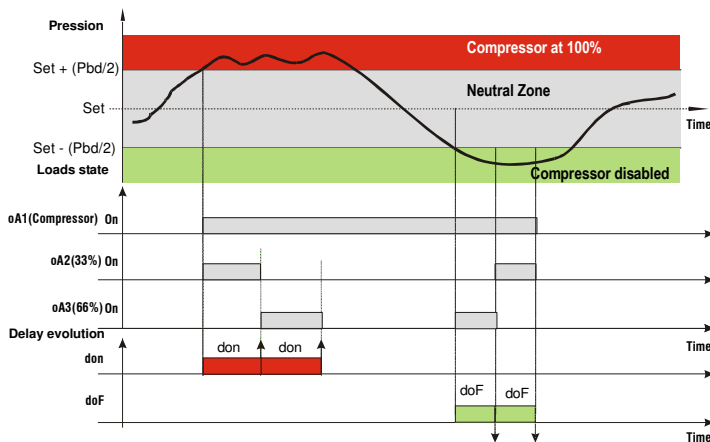

15.2 PROPORTIONAL BAND

The regulation band (Pbd) is divided into as many parts as there are stages according to the following formula:

step = $\sigma A_i = CPr$ or StP (number of compr. or steps).

The numbers of stages switched ON is proportional to the value of the input signal: when this distances itself from the target set point and enters the various bands, the compressors are switched ON, to be then turned OFF when the signal brings near the set point.

In this way if the pressure is greater than regulation band, all the compressors are on, if the pressure (temperature) is lower than the regulation band all the compressors are off.

Naturally also for this regulations all the delays (don and doF) safety times (onon, oFon and donF) are valid.

Regulation according to the running hours

The algorithm switch on and off the loads according to the running hours of each load. In this way the running hours are balanced.

Example: Proportional band control with four steps
In this example:

$\sigma A_1 = cMP$; $\sigma A_2 = StP$; $\sigma A_3 = StP$; $\sigma A_4 = StP$: 4 steps
 $rty = Pb$ proportional band regulation
 $FdLy = no$ "don" delay at first call not enabled.
 $dLF = no$ "doF" delay at first call not enabled.

	Relay 1 - Compressor	Relay valve 1 (25%)	Relay valve 1 (50%)	Relay valve 1 (75%)
25%	ON	ON	OFF	OFF
50%	ON	OFF	ON	OFF
75%	ON	OFF	OFF	ON
100%	ON	OFF	OFF	OFF

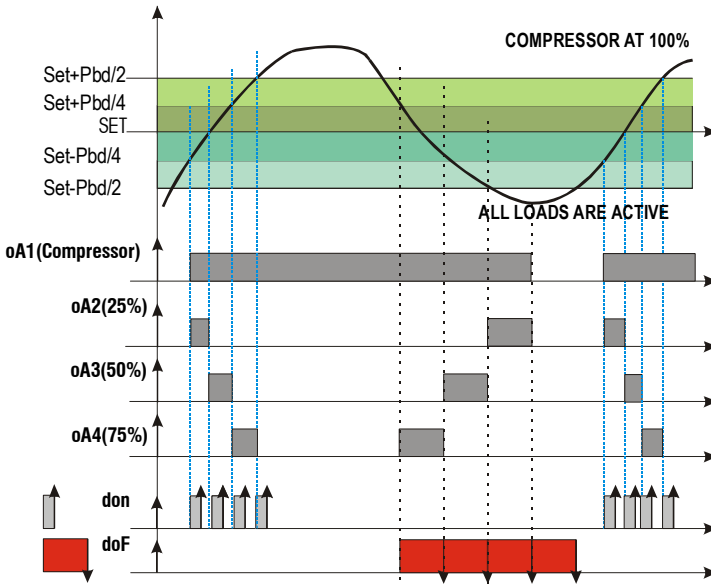

16. Mounting & installation

The instruments are suitable only for internal use. Instruments shall be mounted on panel, in a 29x71 mm hole, and fixed using the special brackets supplied.

To obtain an IP65 protection grade use the front panel rubber gasket (mod. RG-C) as shown in figure. The ambient operating temperature range is between 0÷60 °C.

Avoid locations subject to heavy vibration, corrosive gases or excessive dirt. The same applies to the probes. Ensure ventilation around the instrument.



Figura 1

17. Electrical connections

The controller is provided with removable terminal blocks for wires having section not bigger than 1.0 mm²: 14 ways for analogue and digital inputs, 12 ways for relays

Note: terminals 17-19 are connected inside the controller, they are the common for the "relay n°1" with terminal 15 and "relay n°2" with terminal 16

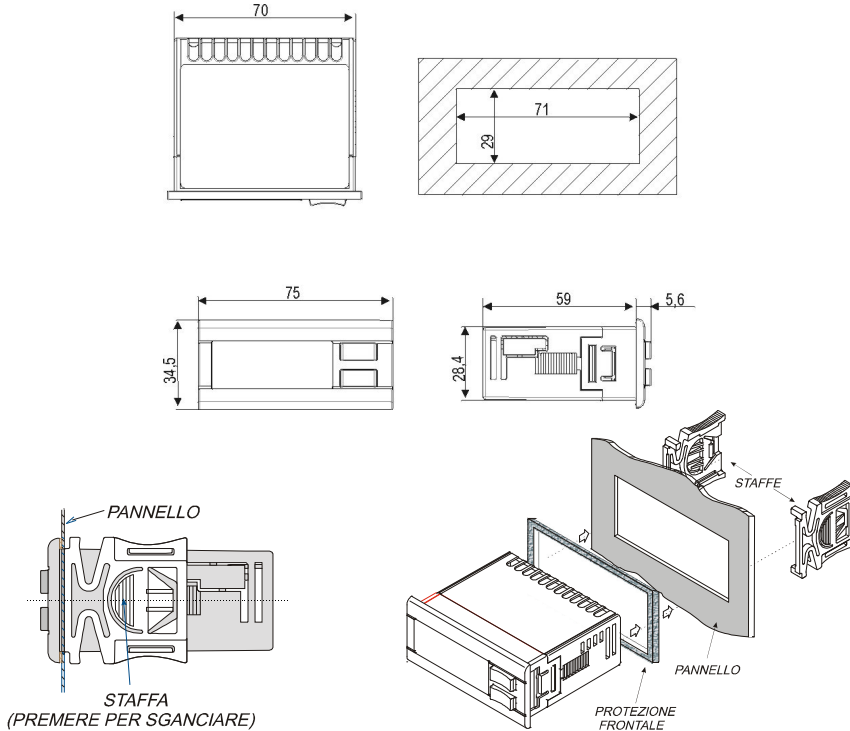
Terminals 21-22 are connected inside the controller, they are the common for the "relay n°3" with terminal 18 and "relay n°4" with terminal 20.

A 5-ways connector is dedicated to the TTL / RS485 interface.

Four connectors having 2-way for 0.2 mm² wires are dedicated to: HP digital input, 12Vdc open collector alarm, LP digital input, 4..20mA analogue output.

Check power supply data before connection wires.

Keep the probe and the digital input wires separate from the power cable.

Do not exceed the maximum rating current for each relay, check technical data and if the load is bigger, use filtered contactors.

Before connecting cables make sure the power supply complies with the instrument's requirements. Separate the input connection cables from the power supply cables, from the outputs and the power connections. **Do not exceed the maximum current allowed on each relay**, in case of heavier loads use a suitable external relay.

17.1 PROBES CONNECTION

Pressure probe (4 - 20 mA): respect the polarity. If using terminal ends be sure there are no bare parts which could cause short circuiting or introduce noise disturbance at high frequencies. To minimise the induced disturbances use shielded cables with the shield connected to earth.

Temperature probe: it is recommended to place the temperature probe away from direct air streams to correctly measure the temperature.

18. RS485 serial link

All models can be integrated into the monitoring and alarm system XJ500 using the TTL serial port. They use the standard ModBus RTU protocol, so they can be fitted in a system integrator using this protocol.

19. Technical features

Housing: Self extinguishing ABS.

Case: Front panel 32x74 mm, depth 60mm ("C" format);

Mounting : "C" format panel mounting in a 29x71 mm panel cut-out

Protection: IP65.

Frontal protection: IP65 with frontal gasket mod RG-C model.

Connections: Removable terminal block 12 and 14 ways;

Power supply: 12Vac/dc \pm 10%, 24Vac/dc \pm 10%, 50-60Hz.

Power absorption: 5VA max.

Display: 3 digits red led and 4 digit orange led.

Inputs: 2 NTC probes, or 2 PTC probes and 2 4..20mA transducer.

Digital inputs: 5 free voltage

Relay outputs: 5 relay SPST 5(3)A, 250Vac

Open collector: alarm output: 12V, 40mA.

Analogue output: 4..20mA for fan control, trigger for fan control

Serial output : TTL standard **Communication protocol:** ModBus – RTU

Data storing: on the non-volatile memory (EEPROM).

Kind of action: 1B; **Pollution grade:** normal; **Software class:** A.

Operating temperature: 0÷60 °C.; **Storage temperature:** -25÷60 °C.

Relative humidity: 20÷85% (no condensing)

Measuring range: NTC probe: -40÷110 °C.

Resolution: 0,1 °C or 1 °C; **Accuracy (ambient temp. 25 °C):** \pm 0,7 °C \pm 1 digit

20. Alarms list

Usually alarm conditions are signalled by means of:

1. Activation of alarm output 0-12V
2. Message on proper display
3. Log of alarm: code and duration.

20.1 TYPES OF ALARMS AND SIGNALLING MANAGED

20.1.1 A12: Configuration alarm

The following configuration parameters are checked after each modification.:

OA1 ÷ OA4	Outputs 1- 4 configuration
P2P	Second probe presence.
dSEP	Dynamic set point enabling
AOP	Probe for analog output
tOP	Probe for triac output

When these parameters are set in wrong way an alarm message is generated:

the label A12 is shown on the upper display, while the lower display signals what wrong setting has created the error:

The following table contains the displayed messages:

Mess.	Errata	Corrige
nLod	Number of loads higher than loads available in the controller	<ul style="list-style-type: none"> Check number of oAi set as load, this number has to be lower or equal to the number of relay of the controller.
cStP	Load (step) configuration error	<ul style="list-style-type: none"> A relay oA(i) has been set as compressor without a previous relay oA(i-1) has been set as compressor. El oA1 = StP
AOP2	P2 probe not available for the 4÷20mA output	<ul style="list-style-type: none"> P2 probe not available P2P =no. Enable the probe setting: P2P =yES The second probe P2 is used to control the temperature of the engine of screw compressors. Check CtyP and set it different from Scr.
dSP2	P2 probe not available for the dynamic set point function	<ul style="list-style-type: none"> P2 probe not available P2P =no. Enable the probe setting: P2P =yES The second probe P2 is used to control the temperature of the engine of screw compressors. Check CtyP and set it different from Scr.
CSP2	P2 probe not available for screw compressor	<ul style="list-style-type: none"> Check CtyP and set it different from Scr.
P2CF	Wrong second probe configuration (El.: If Cty= Scr P2 ha to be PTC)	<ul style="list-style-type: none"> Set P2P = yES and PbC2 = PTC

20.1.2 EOH, EOL Pressure switch alarm, suction and condensing sections

Terminals

Low pressure switch input: 9-10, high pressure switch input: HP.

Parameters

SEP: Low pressure switch polarity: It establishes if the input is activated by closing (SEP=cL) or by opening (SEP=oP) the terminals.

HPP: High pressure switch polarity: It establishes if the input is activated by closing (HPP=cL) or by opening (HPP=oP) the terminals.

Actions

Low pressure: every time the inputs are activated all the compressors are switched off. The instrument restart the standard operating mode when the input is disabled. If there are PE_n activation in the PE_i time, only manual resetting is allowed, by pressing the **DOWN** key for 3s or by turning off and on the instrument.

High pressure: every time the inputs are activated all the compressors are switched off and fans are switched on. The instrument restart the standard operating mode when the input is disabled. If there are PnF activation in the PiF time, only manual resetting is allowed, by pressing the **DOWN** key for 3s or by turning off and on the instrument.

20.1.3 EA1÷EA4: Compressors safeties alarm

Terminals

WARNING: THESE TERMINALS REQUIRE A FREE OF VOLTAGE CONNECTION.

The terminals (from 10, 11, 12, 13, 14+ ID5) really used depends on the number of loads. The protections regarding the compressors and fans are connected to these inputs. If one of these protections is enabling (E.I. for lack of oil or overheating, etc.) the corresponding load is turn off.

Parameters

ALIP: It establishes if the input is activated by closing (ALIP=cL) or by opening (ALIP=oP) the terminals.

Actions

Every time one input is activated the corresponding output is turned off.

Recovery

Recovery depends on **ALMr** parameter:

With **ALMr = no** The instrument restart the standard operating mode when the input is disabled.

With **ALMr = yES** manual recover for the alarms of compressors and fans. Push the **DOWN** key for 3s.

20.1.4 P1: probe failure alarm

It is generated by failure in the probe P1 or P2.

If both compressors and fans are managed by the instrument

SPr: number of steps engaged with faulty probe. (0÷# oAi = cPr or StP) It's used only if CtyP=StP.

FPr: Number of fans engaged with faulty probe. (0÷# oAi = FAN)

If the second probe is used for dynamic set point

The function is disabled and only the standard set point is used.

If the second probe is used for analog output

The function is disabled, the value of the analog output is set in the SAo parameter.

Recovery

Automatic as soon as probe restarts working.

20.1.5 HA, LA High and low pressure (temperature) alarms

This alarm signals that the pressure (temperature) is out of limits established by parameters LAL and HAL for compressors and LAF –HAF for fans.

The **tAo** and **AFd** parameters set the delay between alarm condition and alarm signalling.

Action

The alarm is signalled with standard action. The outputs are unchanged

20.2 ALARM MUTING

Press any buttons to silence the buzzer during an alarm condition.

Hold pressed for more than 3 seconds switch off the alarm relay during an alarm condition

20.3 ALARM CONDITIONS – SUMMARY TABLE

Code	Description	Cause	Action	Reset
A12	Alarm of Instrument configuration	Error in configuration parameters	Every outputs are blocked	View the previous paragraph
E0L	Low pressure-switch alarm	Low pressure switch input enabled	All compressors are turned off. Fans unchanged.	<p>Automatically (if the number of activation are less than PEn in the PEi time) when the input is disable.</p> <ul style="list-style-type: none"> - The compressors restarts working according to the working algorithm. <p>Manually (if PEn activation happened in the PEi time) When the input is disable:</p> <ol style="list-style-type: none"> a. hold pressed the Restart(DOWN)key for 3s or b. turn off and on the instrument.. <ul style="list-style-type: none"> - The compressors restarts working according to the working algorithm.

Code	Description	Cause	Action	Reset
E0H	High pressure switch alarm	High pressure switch input enabled	<ul style="list-style-type: none"> - All compressors are turned off. - All fans are turned on. 	<p>Automatically (if the number of activation are less than PEn in the PEI time) when the input is disable.</p> <ul style="list-style-type: none"> - Compressors and fans restart working according to the working algorithm. <p>Manually (if PEn activation happened in the PEI time) When the input is disable:</p> <ul style="list-style-type: none"> - hold pressed the Restart(DOWN) key for 3s or - turn off and on the instrument. <p>Compressors and fans restarts working according to the working algorithm.</p>
P1	P1 probe failure alarm	Probe failure or out of range	<ul style="list-style-type: none"> - The compressors are activated according to the SP_r or PoPr parameters. 	Automatically as soon as the probe restarts working.
EA1 EA2	Load safeties alarm	<p>Safeties compressor/fan input activation.</p> <p>NOTE: with step compressors 1 input for each compressor has to be used.</p>	<ul style="list-style-type: none"> - the corresponding load is turned off. (with step compressors all relays referred to the input are disabled). 	<p>Recovery depends on ALMr parameter:</p> <p>With ALMr = no The instrument restart the standard operating mode when the input is disabled.</p> <p>With ALMr = YES manual recover for the alarms of compressors and fans. Push the DOWN key for 3s.</p>
LA	Minimum pressure (temperature) alarm compressors section	Suction pressure or temperature lower than SET_C-LAL value	<ul style="list-style-type: none"> - signalling only 	Automatically: as soon as the pressure or temperature reaches the (Set_C-LAL+ differential) value. (differential = 0.3bar or 1°C)
HA	Maximum pressure (temperature) alarm compressors section	Suction pressure or temperature higher than SET_C+HAL value	<ul style="list-style-type: none"> - signalling only 	Automatically: as soon as the pressure or temperature reaches the (Set_C + HAL - differential) value. (differential = 0.3bar or 1°C)
HA2	Maximum pressure (temperature) alarm fans section	Condensing pressure or temperature higher than SET_F+HAL value	<ul style="list-style-type: none"> - signalling only 	Automatically: as soon as the pressure or temperature reaches the (Set_F + HAL - differential) value. (differential = 0.3bar or 1°C)
A5	Liquid level alarm	Input enabled	<ul style="list-style-type: none"> - signalling only 	Automatically as soon as the input is disabled
A14	Load maintenance alarm	A load has worked for the hour set in the SEr parameter	<ul style="list-style-type: none"> - signalling only 	Manually: reset the running hour of the compressor (see par.8 Running hours of loads)

21. Wiring connections

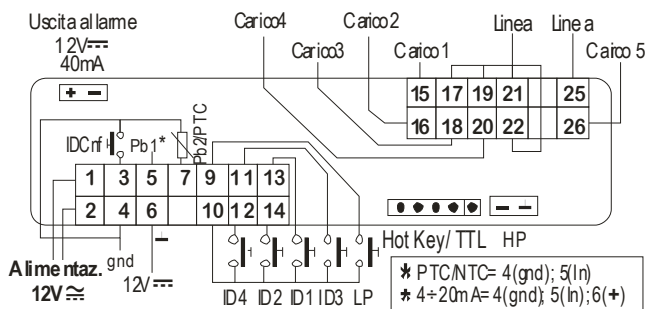

Connessione sonda:
Sonda 4-20mA: P1 = 5(-) - 6(+);
Sonda PTC/NTC: P1 = 5 - 4;

NOTE: l'uscita analogica è un optional.

22. Parameters – Default values

Compressor parameters

Common parameters

Name	°C	°F	bar	PSI	Level	Description	Range
SEtc	-18,0	0	2,3	33	--	Set point for compressors	LSE ÷ HSE
oA1	CPr	CPr	CPr	CPr	Pr2	Outputs 1 configuration	cPr / FAn / StP / ALr / LLn / nu
oA2	StP	StP	StP	StP	Pr2	Outputs 2 configuration	cPr / FAn / StP / ALr / LLn / nu
oA3	StP	StP	StP	StP	Pr2	Outputs 3 configuration	cPr / FAn / StP / ALr / LLn / nu
oA4	StP	StP	StP	StP	Pr2	Outputs 4 configuration	cPr / FAn / StP / ALr / LLn / nu
StP	CL	CL	CL	CL	Pr2	Valve outputs polarity	oP / cL
FtYP	404	404	404	404	Pr2	Freon Type	r22 / 404 / 507 / 134 / 717
rtY	db	db	db	db	Pr2	Type of regulation	db / Pb
StY	yES	yES	yES	yES	Pr2	Compressor rotation	no / YES
Pbc	Cur	Cur	Cur	Cur	Pr2	Probe 1 setting	cur / Ptc / ntc
PA04	0,5	7	0,5	7	Pr2	Adjustment of read out for the Probe at 4mA	0.0 bar o 0 PSI ÷ PA20
PA20	12,0	174	12,0	174	Pr2	Adjustment of read out for the Probe at 20mA	PA04 ÷ 51.0 bar o 750 PSI
cAL	0	0	0	0	Pr2	Probe 1 calibration	-12.0 ÷ 12.0 °C o bar / -20 ÷ 20 °F o PSI
FcAL	0	0	0	0	Pr2	Probe 2 calibration	-12.0 ÷ 12.0 °C o bar / -20 ÷ 20 °F o PSI
SEP	CL	CL	CL	CL	Pr2	Low pressure switch input polarity	oP / cL
HPP	CL	CL	CL	CL	Pr2	High pressure switch input polarity	oP / cL
iFc	cL	cL	cL	cL	Pr2	Configurable digital input polarity	oP / cL
iF	ES	ES	ES	ES	Pr2	Configurable digital input polarity functions	ES / oFF / LL
did	0	0	0	0	Pr2	Configurable digital input delay	0 ÷ 255 min.
ALiP	CL	CL	CL	CL	Pr2	Alarm input for compressors and fans polarity	oP / cL
ALMr	no	no	no	no	Pr2	Manual reset of alarms for compressors and fans	no / YES
dEu	°C	°F	bar	PSI	Pr2	Default measurement unit for displaying	bar / °C / PSI / °F
rES	dE	in	dE	in	Pr2	Resolution for °C and bar	in / dE
rELP	rEL	rEL	rEL	rEL	Pr2	Pressure displaying	rEL / AbS
Pbd	4	8	0.5	7	Pr2	Proportional band or neutral zone width	> 0 ÷ 10.0 bar / 30.0 °C / 80 PSI / 50 °F

Name	°C	°F	bar	PSI	Level	Description	Range
ESc	0	0	0	0	Pr2	Energy saving value for compressors	- + 20.0 bar / - + 50.0 °C / - + 300 PSI / - + 90 °F
onon	5	5	5	5	Pr2	Minimum time between 2 following switching ON of the same compressor	0 ÷ 255 min.
oFon	2	2	2	2	Pr2	Minimum time between the switching off of a compressor and the following switching on	0 ÷ 255 min.
don	0,3	0,3	0,3	0,3	Pr2	Time delay between the insertion of two different compressors	0 ÷ 99.5 min. (res. 10 sec.)
doF	0,1	0,1	0,1	0,1	Pr2	Time delay between switching off of two different compressors	0 ÷ 99.5 min. (res.10 sec.)
donF	0,3	0,3	0,3	0,3	Pr2	Minimum time a stage stays switched ON	0 ÷ 99.5 min. (res.10 sec.)
FdLY	no	no	no	no	Pr2	"don" delay enabled also for the first call	no / YES
FdLF	no	no	no	no	Pr2	doF" delay enabled also for the first switching off	no / YES
odo	20	20	20	20	Pr2	Regulation delay on start-up	0 ÷ 255 sec.
LSE	-40	-40	0,3	5	Pr2	Minimum set point for compressors	PA04 ÷ HSE
HSE	10	50	7,2	100	Pr2	Maximum set point for compressors	LSE ÷ PA20
Lit	100	212	100	212	Pr2	Set point for cooling thermostat	
Lid	10	18	10	18	Pr2	Differential for cooling thermostat	
PAo	30	30	30	30	Pr2	Alarm probe exclusion at power on	0 ÷ 255 min.
LAL	15,0	30	1,5	21	Pr1	Low pressure (temperature) alarm – compressor section	> 0 ÷ 30.0 bar / 100.0 °C / 430 PSI / 200 °F
HAL	20.0	40	2,5	46	Pr1	High pressure (temperature) alarm– compressor section	> 0 ÷ 30.0 bar / 100.0 °C / 430 PSI / 200 °F
tAo	15	15	15	15	Pr1	Low and High pressure (temperature) alarms delay–compressor section	0 ÷ 255 min.
SEr	999	999	999	999	Pr2	Service request	(0 = disable) 1 ÷ 999; res 10h
PEn	5	5	5	5	Pr2	Low pressure-switch intervention numbers	0 ÷ 15
PEi	15	15	15	15	Pr2	Pressure-switch interventions time	0 ÷ 255 min.
SPr	2	2	2	2	Pr2	Number of steps engaged with faulty probe	0 ÷ # compressors
PnF	5	5	5	5	Pr2	High pressure-switch intervention numbers – fans section	0 ÷ 15
PIF	15	15	15	15	Pr2	Pressure-switch interventions time – fans section	0 ÷ 255 min.
tbA	yES	yES	yES	yES	Pr2	Alarm relay silencing	no / YES
oFF	no	no	no	no	Pr2	Switching ON/OFF enabling from keyboard	no / YES
Ad1	1	1	1	1	Pr2	Compressors address	1 ÷ 247
Ptb	-	-	-	-	Pr1	Parameter table code	readable only
Pr2					Pr1	Password protected menu	readable only

dixell S.p.a.

Z.I. Via dell'Industria, 27 - 32010 Pieve d'Alpago (BL) ITALY
tel. +39 - 0437 - 98 33 - fax +39 - 0437 - 98 93 13

<http://www.dixell.com> E-mail: dixell@dixell.com